

INSTRUCTION

MODEL **MF-79**



NARISHIGE SCIENTIFIC INSTRUMENT LAB.

9-28 KASUYA 4-CHOME SETAGAYA-KU, TOKYO 157, JAPAN
PHONE(INT-L)81-3-3308-8233, FAX(INT-L)81-3-3308-2005
CABLE:NARISHIGELABO, TELEX, NARISHIGE J27781



株式
会社

成茂科学器械研究所

東京都世田谷区粕谷4丁目9番28号 〒157
PHONE 03-3308-8233 FAX 03-3308-2005

General

Thank you for purchasing the Narishige MF-79 Microforge (for miniature tools). This instrument is designed for processing the tips of glass micropipettes produced by a pipette puller. The MF-79 is perfect for producing micropipettes for injection, cutters, spoons and other miniature tools. Fire-polishing is also available to make pipette tips round and smooth.

Names of the principal parts

- ① Rotating Disc
- ② X-Y Stage
- ③ Heater Holder
- ④ Transmitting Illuminator
- ⑤ Heater Manipulator
- ⑥ Illumination Control
- ⑦ Footswitch Connector
- ⑧ Footswitch
- ⑨ Power Switch
- ⑩ Pipette Manipulator
- ⑪ Air Nozzle
- ⑫ Eyepieces
- ⑬ Microscop
- ⑭ Air Tube

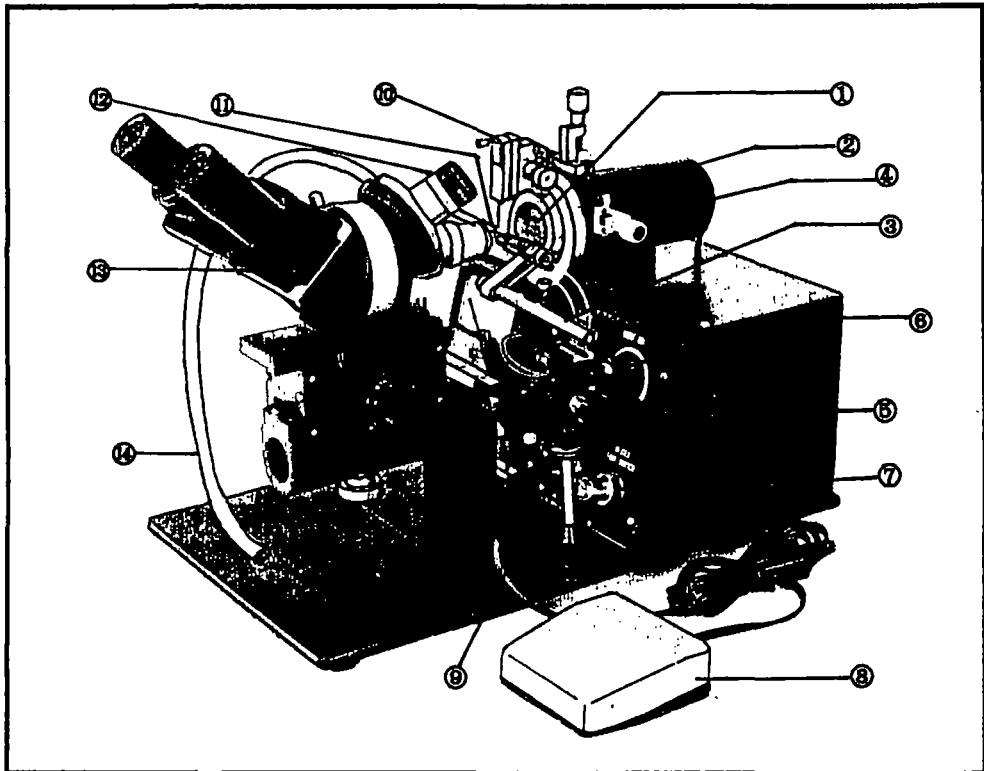

Specifications

| | |
|-----------------------------|--|
| MF-79 Specifications | Microforge (for miniature tools) |
| Power Box | : Power Input - 100V AC Output Terminal - 1/2/3/4/6V 3A |
| Microscope | : Objectives - 10X, 4X Eyepieces - WF10X |
| Heater Manipulator | : X-Axis/30mm (Coarse), Y-Axis/23mm (Coarse), Z-Axis/22mm (Fine), Joystick for X-Y Plane (Fine) |
| Heater | : Platinum Wire (100 μ m) |
| Heater Ammeter Scale | : 0 - 3A |
| Dimensions | : 350 (W) X 205 (D) X 255 (H) mm |
| Weight | : 9.8 Kg |
| Accessories | : Footswitch 1 EA Heater 1 EA Lamp 1 EA |

Construction

The MF-79 consists of the following sections:

1. Main body base and Power Sources Housing

- 1) The base is made from light alloy plate and equipped with each support rod.
- 2) The housing has the power sources for heater and built-in illumination.
- 3) Glass pipette manipulator and transmitting illuminator with associated control are mounted on the surface of the housing.

2. Microscope

Binocular microscope and scope body.

3. Manipulators

- 1) For glass pipette (rotating disc type)
- 2) For heater (joystick type)
- 3) For air nozzle (ball joint type)

Assembly

1. Connect the cord at the rear of the transmitting illuminator, with the back light plug.
2. Assembling of the microscope.
Next, when setting the binocular microscope to the scope body, put on the power switch, and switch on the transmitting illuminator (back light) and set the binocular microscope so that the intersecting point of the cross line of the rotating disc of the pipette manipulator can be focussed on the center of visual field.
3. Set up the joystick heater manipulator in the support rod at the right of the microscope. This manipulator is arranged to move the heater element in two planes (forward up and down) with rack and pinion adjustments and a fine screw drive in the lateral direction. The platinum heater is fixed in the head of the heater holder. Connect the cord of the heater with the heater clamp.
4. The air ball joint manipulator can be installed in the support rod at the left of the microscope. This manipulator can move backward and forward. Adequate travel ranges are provided in all directions.
5. Positioning of the heater and air nozzle.
 - 1) Make up the heater form convenient to working the minute pipettes (Refer to Page 5).
 - 2) The injection needle generally used as an air nozzle should have its thickness conforming to the volume of flowing air. Set the air nozzle at the appropriate position for operation.

Operation

1. Before turning the power switch on, please carry out strictly the following items, in order to prevent the heater from burning out by overcurrent.
 - 1) Set the dial for heater control at ' 0 '.
 - 2) Put the heater switch at ' OFF '.
2. Put the power switch on, pilot lamp on.
 - 1) Appropriate illuminance can be provided from darkness to full brilliancy, by the dial for illumination control.
 - 2) Put the micropipette (pulled with the microelectrode puller) in the pipette fixing groove of the pipette manipulator and set the forming portion to be worked of the pipette at the center of visual field.
 - 3) Set the heater switch at IV and put up gradually the dial for heater control until the radiation of the platinum heater becomes yellow bright. If it does not become yellow bright even at IV. Turn the dial at 2V or 3V.

When the platinum heater is burnt out, put a new heater into the head point of the heater holder as shown below.

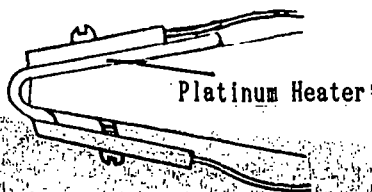

- 4) The pipette will be worked precisely by operating the heater manipulator with your right hand, rotating the dial for heater control with your left hand, and holding the air tube in your mouth.

Guidelines for use

NOTE : The MF-79 is a precision instrument. It is intended to produce glass pipettes in the micron size range.

Please observe the following guidelines when operating the MF-79.

1. Handle carefully and avoid dropping or jarring.
2. Do not disassemble the unit.
3. Keep foreign materials i.e. blood, drugs etc. from contacting the equipment. Keep out of direct sunlight.
4. Please call a representative if you have any questions regarding use of the MF-79.

Processing Technique

Technique #1

Various techniques can be used to produce various microtools such as:

- Heat processing
- Cooling by air
- Micromanipulating the pipette
- Rotating the pipette with the rotating disk
- Controlling footswitch

1. How to bend the pipette:

If the heater filament is positioned close to the pipette shaft, the pipette will bend with the upward flow of hot air. Rotating the pipette with the rotating disk will maximize the bend.

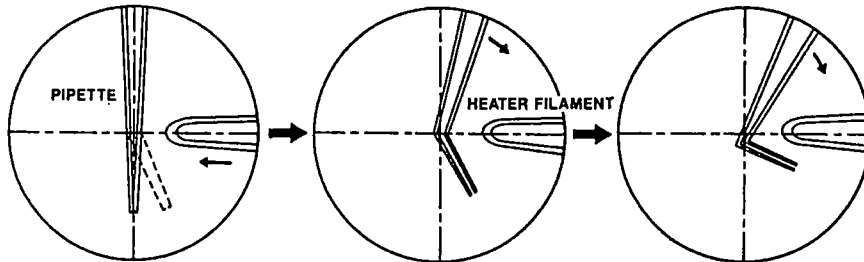

2. How to make a fine point:

A. When the heater filament is placed so that it touches the pipette tip, the glass tip melts. While the melting takes place, pull the heater filament away from the pipette quickly as shown in the illustration. This results in the tip of a very fine needle point.

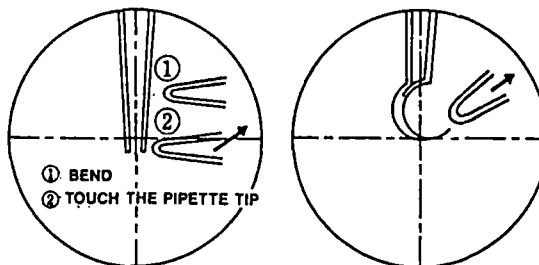

B. When the heater filament is close to the pipette, the pipette will bend with the upward flow of hot air. Then use step A. to draw the tip to a very fine needle point.

The MF-79 can produce a variety of microtools with various shapes. Selecting the proper heater filament configurations is very important. Also, using the microscope positioning knobs properly is essential.

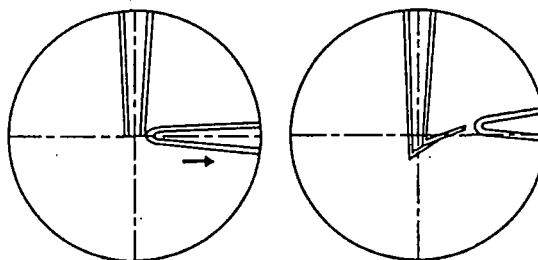

Processing Technique

Technique #2

3. How to make a ring:

A ring can be fabricated by using the upward flow of hot air and rotating the pipette with a rotating disk. A ring will be completed by repeating the procedure of bending.

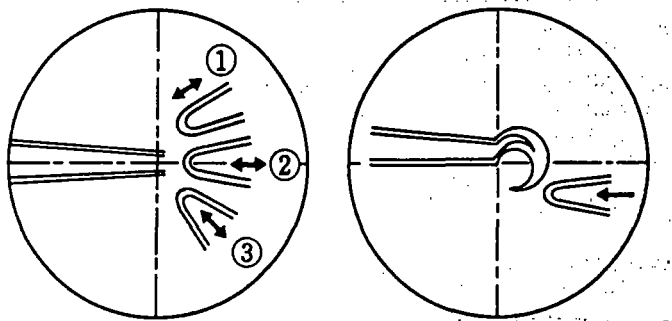

4. How to make a dent:

Heating and operating the pipette as shown in the illustration will result in a transformation of the tip. Turning off the heater filament and cooling will cure the glass.

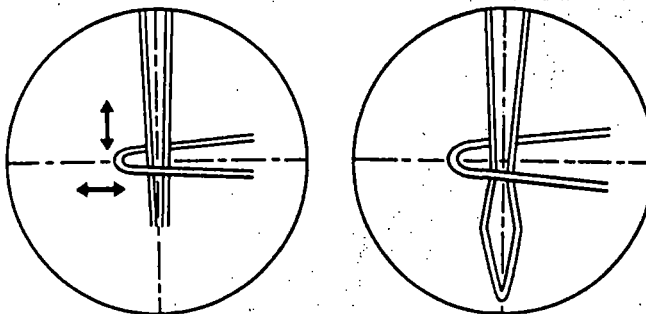

5. How to make a closed needle point:

Add weight, such as clay, to the end of the pipette. The tip of the pipette will separate with the combination of heat and gravity.

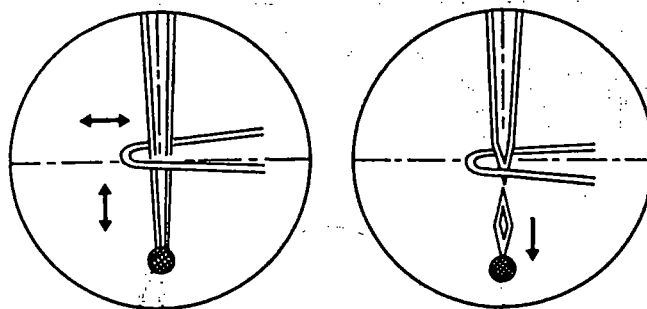

MN-3

Three Dimensional Manipulator

INSTRUCTION MANUAL

Biotechnology is reaching higher levels and becoming more diverse.

Nowadays, biotechnology is expanding its range of applications into a wide variety of industries, from agriculture, food products, chemicals, pharmaceuticals, and medicine to energy production.

Narishige is continuing its product development based on its fundamental philosophy of making it easy to obtain the highly precise micromanipulation required for research in these fields.



NARISHIGE CO., LTD.

Introduction

Thank you for purchasing the Narishige MN-3 manipulator

The MN-3 is a three dimensional direct drive coarse positioning manipulator for the initial rapid positioning of the micropipette prior to fine micromanipulation. It is used in combination with the drive unit of various hydraulic remote control micromanipulators such as the MO-202 (Joystick 3 dimensional hydraulic micromanipulator) or the MO-303 (Ultra fine, low drift 3 dimensional hydraulic micromanipulator).

The MN-3 manipulator is made of light alloy and is of a compact design. It can be mounted on either the right hand or left hand side of a microscope and is easily attached to the microscope mounting adaptor with two fixing screws (see photograph beneath).

The MN-3 manipulator is for use with microscope mounting adaptors that attach at the stage level of the microscope. Vibration transmitted by the operator is minimized and the movements of the mechanical stage of the microscope are not inhibited.

The P-3 fixing plate is fitted to the main body of the MN-3 and then the drive unit of the hydraulic remote control micromanipulator is fitted to the P-3 fixing plate. The configuration of the complete assembly is designed to ensure optimum performance by keeping the distance between the fixing point of the hydraulic drive unit and the tip of the micropipette to a minimum.

After the MN-3 manipulator has been used for the initial coarse positioning of the micropipette each of its 3 axes can be clamped by means of locking screws. This ensures any subsequent movement or vibration from the MN-3 manipulator is totally eliminated.

If the P-3 fixing plate, supplied with the MN-3 manipulator, is replaced with a P-2 fixing plate, the MN-3 can be converted to an MN-2 for use with hydraulic micromanipulators such as the MO-202 and MO-303. The MN-2 is the type of coarse positioning manipulator for use when the micromanipulator is mounted to the lighting support arm of inverted microscopes.

If the P-3 fixing plate, supplied with the MN-3 manipulator, is replaced with a P-1 fixing plate, the MN-3 can be converted to the equivalent of an MN-1 type manipulator. The MN-1 manipulator is the type required for use with the older types of hydraulic manipulators.

Left Hand Use Right Hand Use



Items Supplied

The MN-3 manipulator is made up of parts shown in the photograph below. Please check all the parts are included.

1. Main Unit
2. P-3 fixing plate with height adjustment (see right hand photograph) made up of the following items.
 - a. Height adjustment plate Qty 1
 - b. Spacer Qty 2
 - c. Fixing screw for main unit (6 x 20mm) Qty 2
 - d. Fixing screw for plates a. and b. (6 x 40mm) Qty 2
 - e. Allen key (for 6 mm fixing screw) Qty 1

P-3

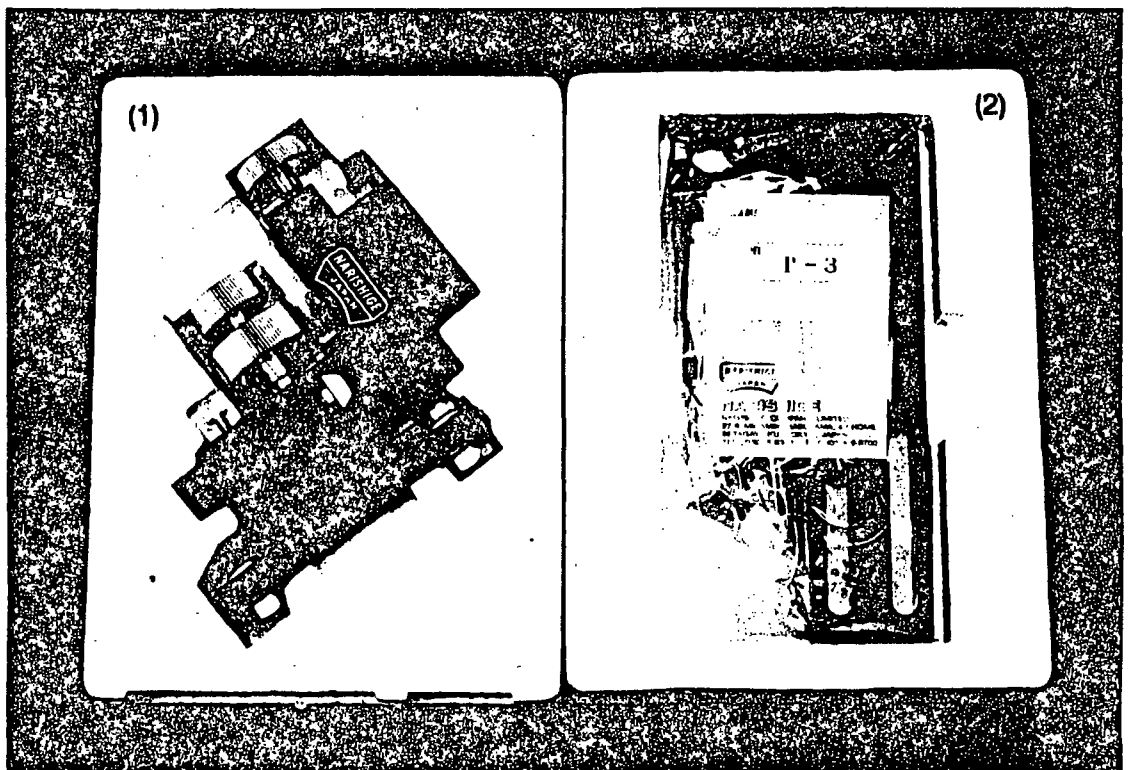
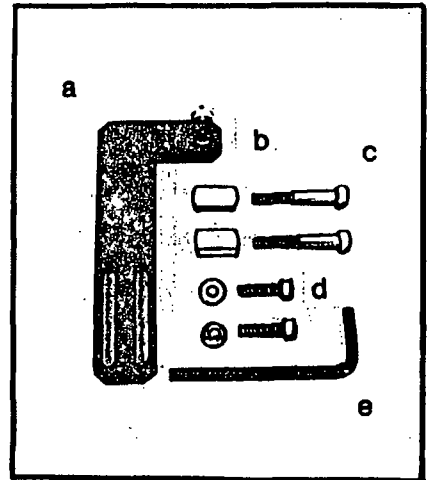

The Components and Their Function

(For right hand use)

1. X-Axis Control Knob
Rotation of the control knob moves the micropipette in the X direction (right and left). Clockwise rotation moves the micropipette to the right and counterclockwise rotation moves it to the left.
The range of movement is 30 mm.
2. Y-Axis Control Knob
Rotation of the control knob moves the micropipette in the Y direction (forwards and backwards). Clockwise rotation moves the micropipette backwards and counterclockwise rotation moves it forwards.
The range of movement is 30 mm.
3. Z-Axis Control Knob
Rotation of the control knob moves the micropipette in the Z direction (up and down). Clockwise rotation moves the micropipette downwards and counterclockwise rotation moves it upwards.
The range of movement is 25 mm.
4. Z-Axis Clamp
Tighten the locking screw after coarse positioning of the micropipette. Do not attempt to adjust the Z-axis when the movement is clamped.
5. Y-Axis Clamp
Tighten the locking screw after coarse positioning of the micropipette. Do not attempt to adjust the Y-axis when the movement is clamped.

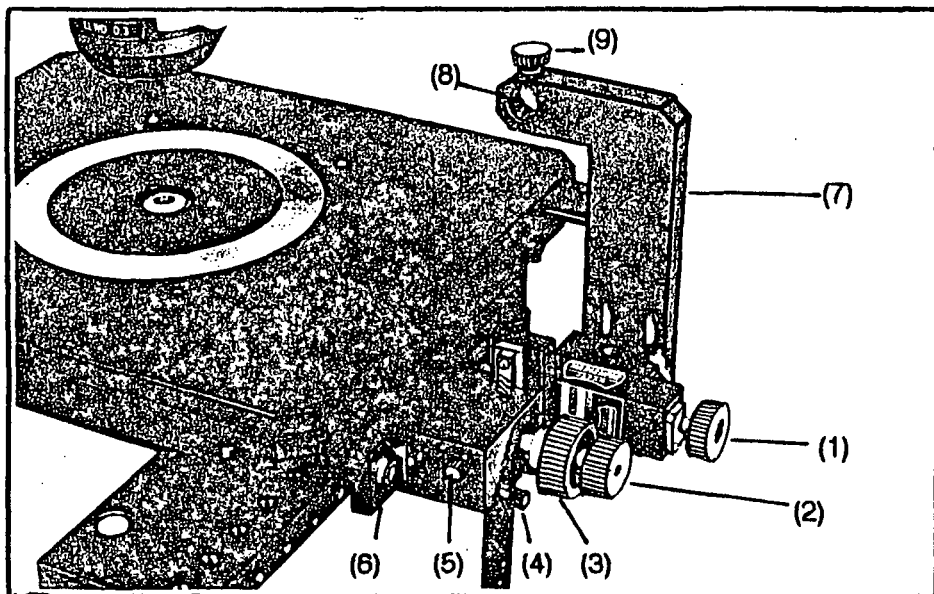

- 6. Holes for Fixing Screws to Mounting Adaptor**
Attach the MN-3 manipulator to the mounting adaptor and tighten the two screws securely to prevent vibration.
- 7. P-3 Fixing Plate**
This is used to attach the drive unit of some types of hydraulic micro-manipulators (such as the MO-202/203 or the MO-302/302) to the MN-3 manipulator. Coarse positioning of the fine hydraulic micromanipulator is carried out with the MN-3 manipulator. The positioning of the P-3 fixing plate enables the height of hydraulic unit above the MN-3 manipulator to be adjusted. Spacers are also provided. The spacers are used if necessary.
- 8. Holes for Fixing Bar**
The fixing bar of the hydraulic micromanipulator drive unit is inserted into either of these holes. Select the hole that achieves the minimum distance from the fixing bar to the micropipette tip.
- 9. Locking Screw for Fixing Bar**
Lock the hydraulic micromanipulator drive unit fixing bar into the appropriate hole (8).
- 10. X-Axis Clamp.**
Tighten the locking screw after coarse positioning of the micropipette. Do not attempt to adjust the X-axis when the movement is clamped.

Assembly Instructions

Assembly and Attachment of P-3 Fixing Plate

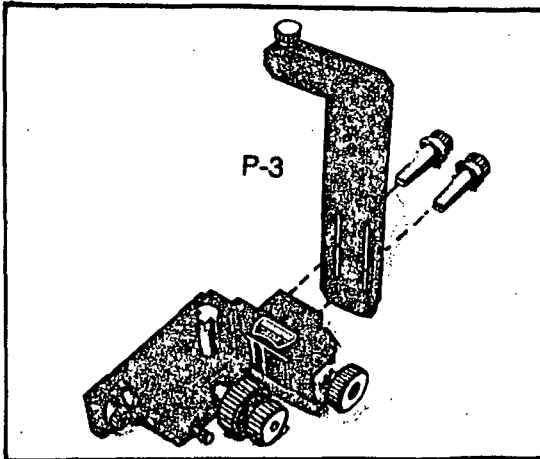

Refer to left hand photograph
Attach the P-3 fixing plate to the main body of the MN-3 manipulator by means of the two 6 x 20 mm fixing screws. If it is necessary to use the spacers put them between the main body and the P-3 fixing plate and use the 6 x 40 mm fixing screws. Clamp the P-3 fixing plate at the appropriate height.

Right Hand Use

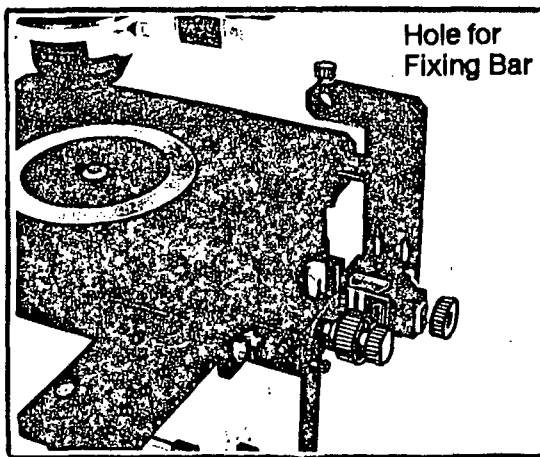

Attach the microscope mounting adaptor to the microscope.
Attach the MN-3 in the appropriate position, to the right hand side of the microscope mounting adaptor with the two 6 mm fixing screws.
Fit the hydraulic micromanipulator drive unit to the MN-3 by inserting and clamping the fixing bar into the hole in the P-3 fixing plate.

Left Hand Use

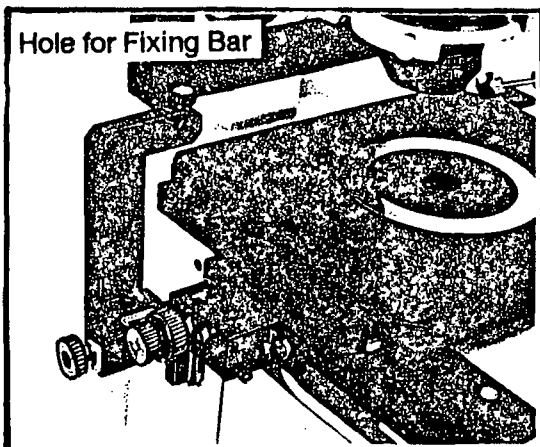

Attach the microscope mounting adaptor to the microscope.
Attach the MN-3 in the appropriate position to the left hand side of the microscope mounting adaptor with two 6 mm fixing screws.
Fit the hydraulic micromanipulator drive unit to the MN-3 by inserting and clamping the fixing bar into the hole in the P-3 fixing plate.

Precautions

The MN-3 is a high precision piece of equipment which, before despatch has been carefully adjusted in our factory. Please observe the following:

1. Handle with care and avoid any jolts or knocks.
2. Do not attempt to adjust or dismantle the equipment. In the event of the equipment requiring any adjustment please return it to your nearest authorized repair center.
3. Avoid spillage on the equipment. In the event of such an accident occurring clean immediately with an organic solvent such as alcohol. Do not sterilize by boiling.
4. When not in use, keep the equipment away from direct sunlight and protect from dust. If it is necessary to clean the equipment use a dry soft cloth.

If you do have any problems, questions or comments please contact us.

Specification

The MN-3 specification

Three dimensional direct drive coarse positioning manipulator unit.

Range of movement: X-axis coarse movement 30 mm
Y-axis coarse movement 30 mm
Z-axis coarse movement 25 mm

Material: Light alloy

Weight: Approx. 310g

Accessory P-3 Fixing plate with height adjustment
(Weight: Approx. 110g)

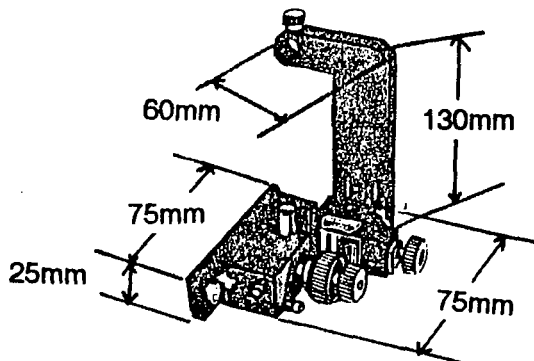

MO-203

Three Dimensional Hydraulic Micromanipulator

INSTRUCTION MANUAL

Biotechnology is reaching higher levels and becoming more diverse.

Nowadays, biotechnology is expanding its range of applications into a wide variety of industries, from agriculture, food products, chemicals, pharmaceuticals, and medicine to energy production.

Narishige is continuing its product development based on its fundamental philosophy of making it easy to obtain the highly precise micromanipulation required for research in these fields.



NARISHIGE CO., LTD.

Instruction Manual
for
MO-203 Three Dimensional Hydraulic
Micromanipulator

Thank you for purchasing the Narishige MO-203 Hydraulic Micromanipulator. The MO-203 has been built with pride and should give you years of trouble-free operation. This manual is designed to help you get maximum performance from your MO-203. If after reading it you require further assistance, please never hesitate to call us directly to speak with one of our applications specialists.

Unpacking

The MO-203 has been carefully packed and inspected, a picture of the package contents is shown below. You should have one (1) of each of the items shown. Should any of the parts arrive in a damaged condition, contact your common carrier immediately. Do not call us since corrective action must start with the carrier. Be assured that we will cooperate completely to help correct the problem and to have you operational quickly.

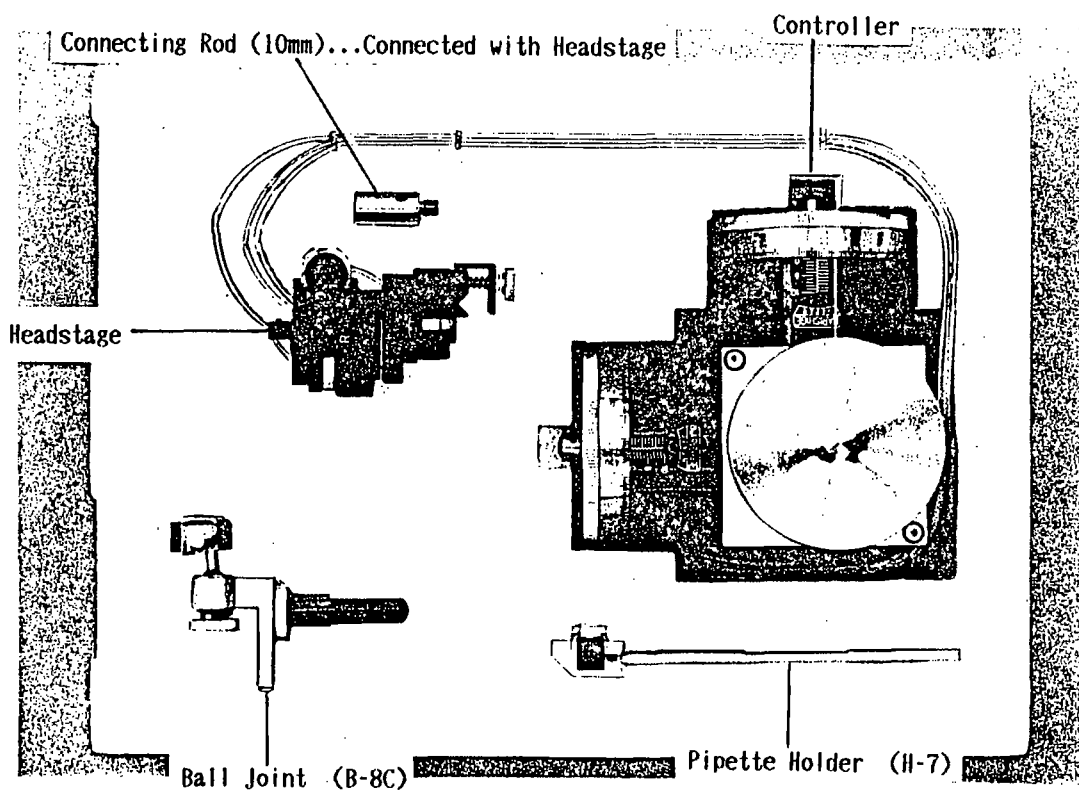

The MO-203 is a compact, vibration-free, three dimensional hydraulic micromanipulator. Smooth microdrive movement through a 10mm range is remotely and independently controlled for each of the X, Y and Z axes. The smooth vibration-free movement of the microdrive makes the MO-203 ideal for inserting microelectrodes into small cells or culture.

This manipulator is light-weight and is designed to be mounted on a microscope using specific adaptors which enhance the vibration-free movement.

This MO-203 manipulator is designed for both Right hand and Left hand use. Adjust both the headstage and controller so that the printed "R" is facing the user when Right hand use applies. Do the same for Left hand use while making sure that the printed "L" is facing the user.

In order to connect the headstage with the coarse movement manipulator (MN-2), you should screw the connecting rod into the back of the headstage. In case of Right hand use, the connecting rod should be screwed into the hole indicated "R". In case of Left hand use, screw the connecting rod into the hole indicated "L".

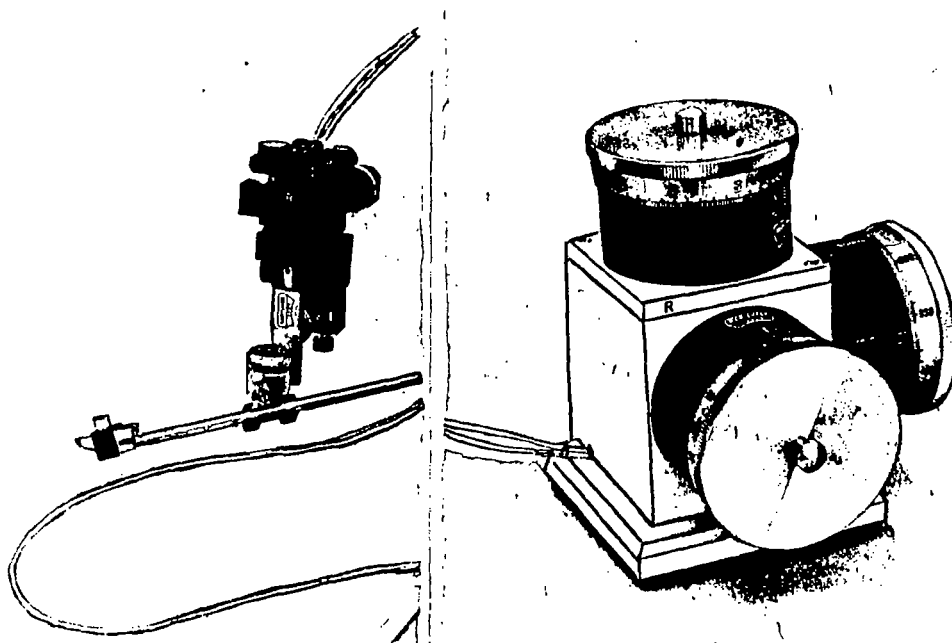

Principal Parts of the Headstage

When the headstage is positioned to face "R" in front, you can use it for Right hand use. When positioning to face "L" in front, you can use it for Left hand use.

Right Hand Use

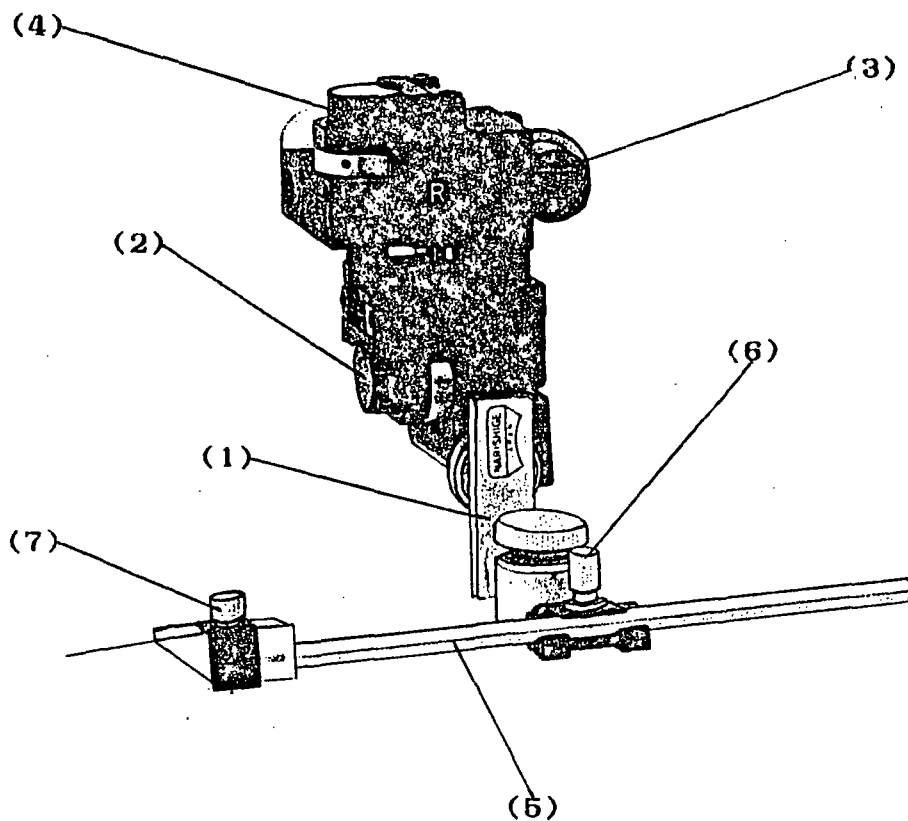

- (1) Ball Joint B-8C
- (2) X-unit for Right hand use, Y-unit for Left hand use
- (3) Y-unit for Right hand use, X-unit for Left hand use
- (4) Z-unit
- (5) Pipette Holder H-7
- (6) Pipette Holder Fixing Screw
- (7) Pipette Fixing Screw

Principal Parts of the Controller

- (1) Z-axis Control Knob
- (2) X-axis Control Knob for Right hand use
Y-axis Control Knob for Left hand use
- (3) Operation Scale
- (4) Controller Housing
- (5) Y-axis Control Knob for Right hand use
X-axis Control Knob for Left hand use

Right Hand Use

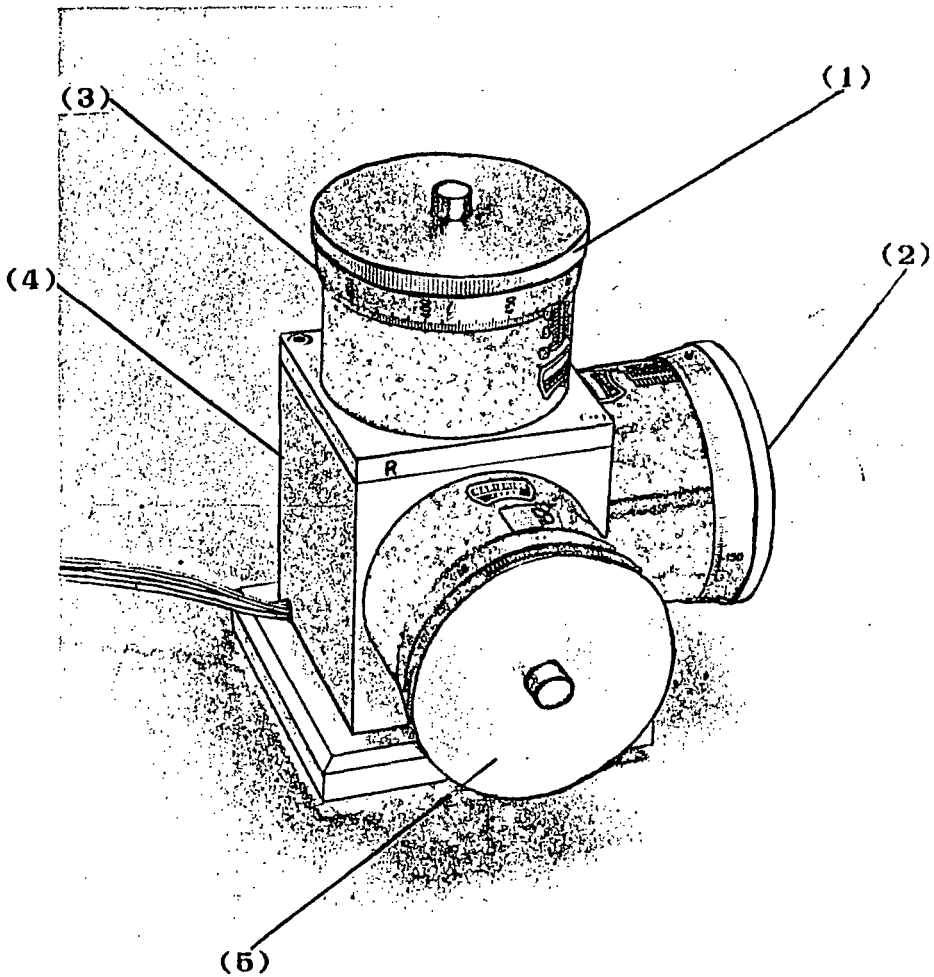

The Headstage

The headstage of the MO-203 is composed of three microdrive units which are assembled at right angles from each other, so as to represent X, Y and Z movements. A micropipette can be moved to any point within a 10mm sided cube by making use of hydraulic pressure which is directed from a remotely located controller.

The following parts are necessary when mounting the headstage to various microscopes.

- (1) Adaptor for type of Microscope (See catalog for applicable part number(s))
- (2) MN-2 (or MN-3) Coarse movement Manipulator

The headstage must be mounted so that the printed "R" is facing the user when Right hand use applies. In case of Left hand use, turn the headstage to the left 90 degrees so that the printed "L" is facing the user.

In order to connect the headstage with the coarse movement manipulator MN-2, you must screw the supplied connecting rod into the back of the headstage. When Right hand use applies, screw the connecting rod into the hole marked "R". For Left hand use, screw the connecting rod into the hole marked "L".

After mounting the headstage completely to the microscope, rotate the knobs of the Controller so as to make sure that each knob is controlling the correct axis.

The Controller

The Controller is made up of three operation knobs (1) (2) (5) which control independent movement along all three axes.

Working Distance

Headstage: X-axis

Y-axis

Z-axis

Fine Movement

Movable Distance 10mm each

Controller: X, Y and Z Direction

Fine Movement

Controllable Distance 10mm each

One rotation of the knob results in the movement of the microdrive by 500 microns, while the minimum scale of the control knob for X, Y and Z stands for 2 microns.

Accessories

| | | |
|--------------------|------|------|
| (1) Pipette Holder | H-7 | 1 ea |
| (2) Ball Joint | B-8C | 1 ea |

Handling and Maintenance of the Instrument

This precision instrument is delicate and should be handled with care. Avoid any shock to the instrument. Be aware that pulling on the hydraulic lines can result in damaging the sealed hydraulic system. Keep in mind that this system is sensitive to temperature change. To minimize unwanted movement of the headstage, keep MO-203 in a stable temperature environment away from drafts and sun.

After long term use, the oil may change color. This is due to oxidation of the oil. This change should not affect the instrument's performance.

After each use turn all three vernier controls to their zero positions in order to prevent excessive oil leakage through diaphragm. (A small amount of oil leakage is inevitable and should not be regarded as a defect in the device.)

For best results when operating the M0-203 each of the vernier controls should be at the mid-range of their 10mm travel.

• Never attempt to disassemble a control cylinder. If so, this will make re-adjustment very difficult.

The oil containers of the microdrives and controller are of a cartridge design so that repair is a matter of replacing the cartridge.

If problems occur with the system, please do not attempt to repair, but rather contact us and we will repair it for you.

David Kleinfeld
Room 6H-424
ATT Bell Laboratories
600 Mountain Avenue
Murray Hill, N.J. 07974

INSTRUCTIONS

MO-203



NARISHIGE co., LTD.

27-9, MINAMIKARASUYAMA 4-CHOME, SETAGAYA-KU, TOKYO, JAPAN.

TEL: (03) 308-8383 CABLE: NARISHIGELABO

FACSIMILE: (03) 308-8700



株式
会社

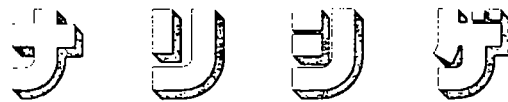

〒157 東京都世田谷区南烏山4丁目27番9号
TEL.(03)308-8383 FAX.(03)308-8700

Instruction Manual
for
MO-203 Three Dimensional Hydraulic
Micromanipulator

Thank you for purchasing the Narishige MO-203 Hydraulic Micromanipulator. The MO-203 has been built with pride and should give you years of trouble-free operation. This manual is designed to help you get maximum performance from your MO-203. If after reading it you require further assistance, please never hesitate to call us directly to speak with one of our applications specialists.

Unpacking

The MO-203 has been carefully packed and inspected, a picture of the package contents is shown below. You should have one (1) of each of the items shown. Should any of the parts arrive in a damaged condition, contact your common carrier immediately. Do not call us since corrective action must start with the carrier. Be assured that we will cooperate completely to help correct the problem and to have you operational quickly.

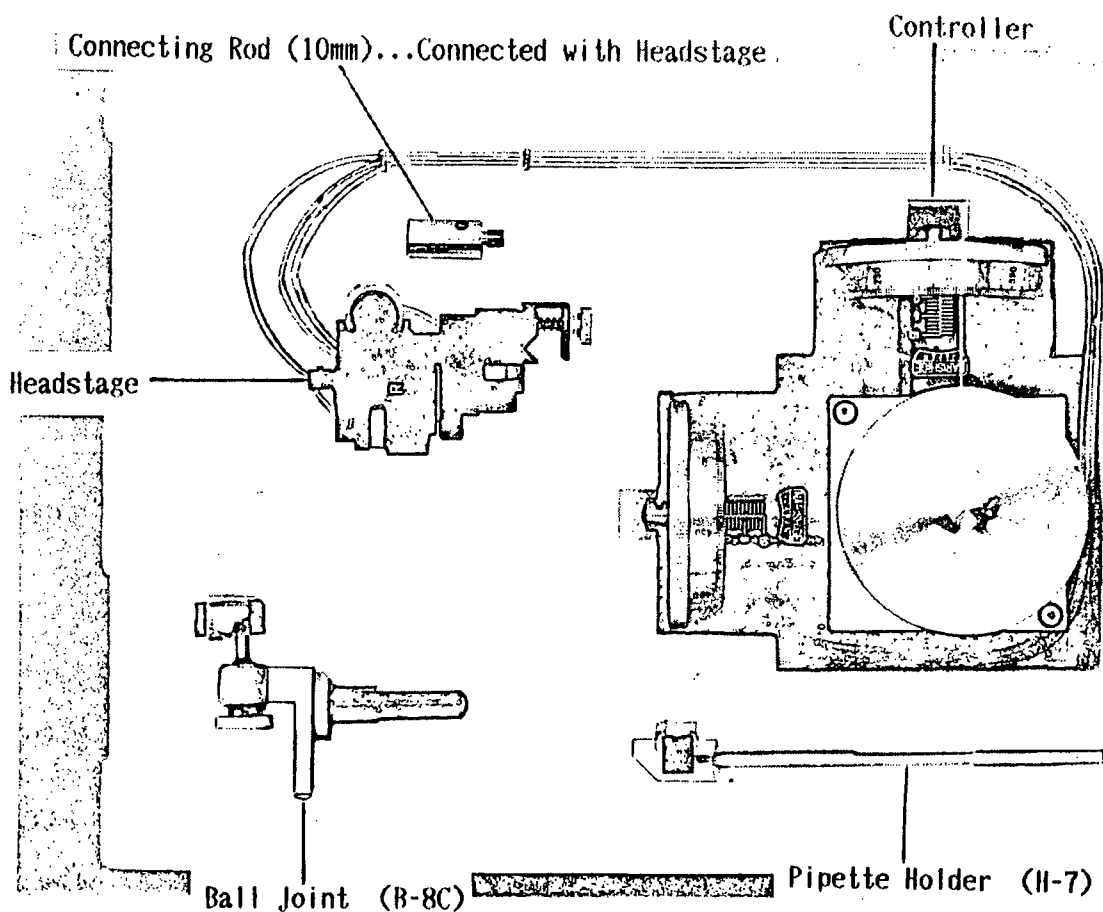

The MO-203 is a compact, vibration-free, three dimensional hydraulic micromanipulator. Smooth microdrive movement through a 10mm range is remotely and independently controlled for each of the X, Y and Z axes. The smooth vibration-free movement of the microdrive makes the MO-203 ideal for inserting microelectrodes into small cells or culture.

This manipulator is light-weight and is designed to be mounted on a microscope using specific adaptors which enhance the vibration-free movement.

This MO-203 manipulator is designed for both Right hand and Left hand use. Adjust both the headstage and controller so that the printed "R" is facing the user when Right hand use applies. Do the same for Left hand use while making sure that the printed "L" is facing the user.

In order to connect the headstage with the coarse movement manipulator (MN-2), you should screw the connecting rod into the back of the headstage. In case of Right hand use, the connecting rod should be screwed into the hole indicated "R". In case of Left hand use, screw the connecting rod into the hole indicated "L".

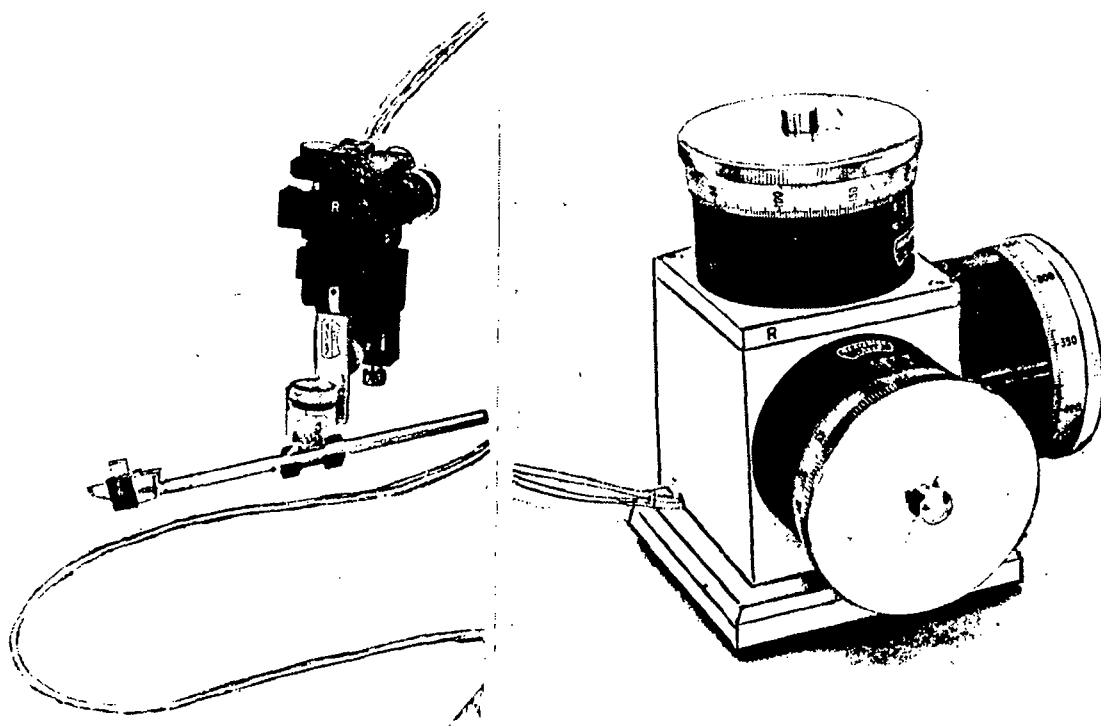

Principal Parts of the Headstage

When the headstage is positioned to face "R" in front, you can use it for Right hand use. When positioning to face "L" in front, you can use it for Left hand use.

Right Hand Use

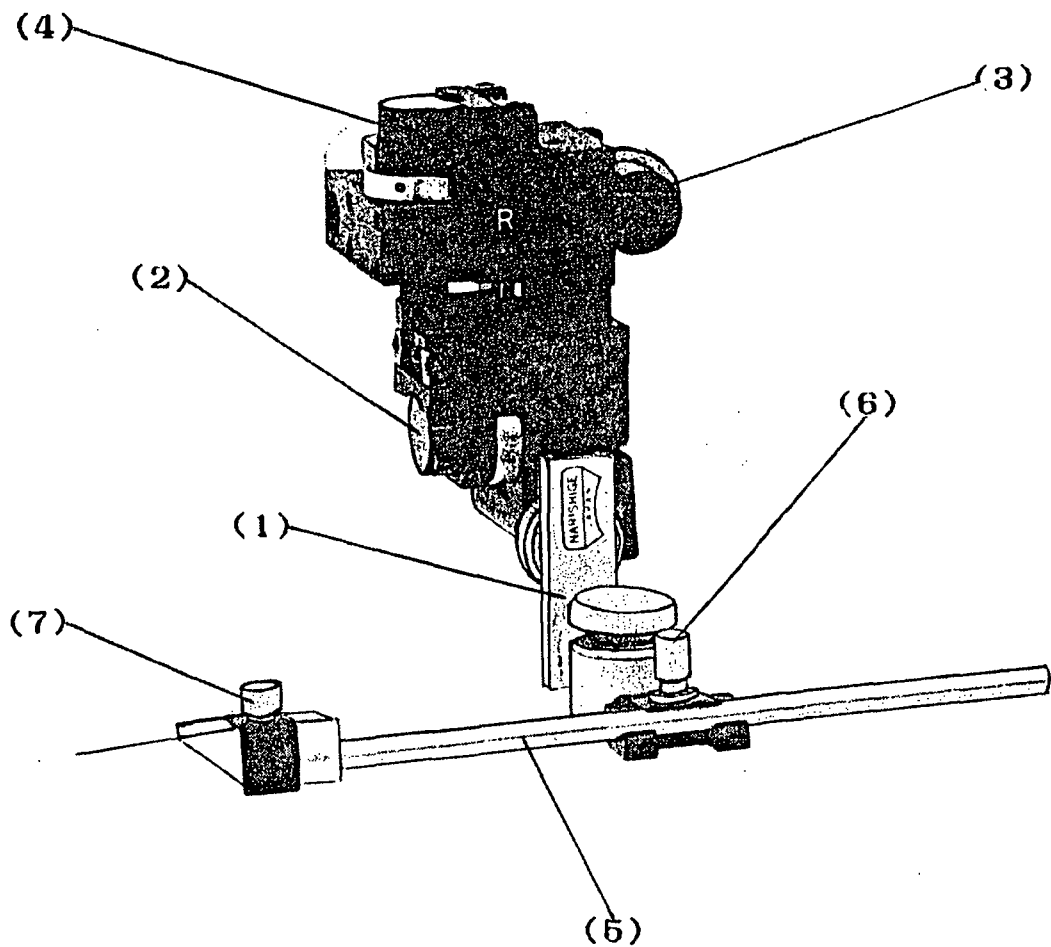

- (1) Ball Joint B-8C
- (2) X-unit for Right hand use, Y-unit for Left hand use
- (3) Y-unit for Right hand use, X-unit for Left hand use
- (4) Z-unit
- (5) Pipette Holder H-7
- (6) Pipette Holder Fixing Screw
- (7) Pipette Fixing Screw

Principal Parts of the Controller

- (1) Z-axis Control Knob
- (2) X-axis Control Knob for Right hand use
Y-axis Control Knob for Left hand use
- (3) Operation Scale
- (4) Controller Housing
- (5) Y-axis Control Knob for Right hand use
X-axis Control Knob for Left hand use

Right Hand Use

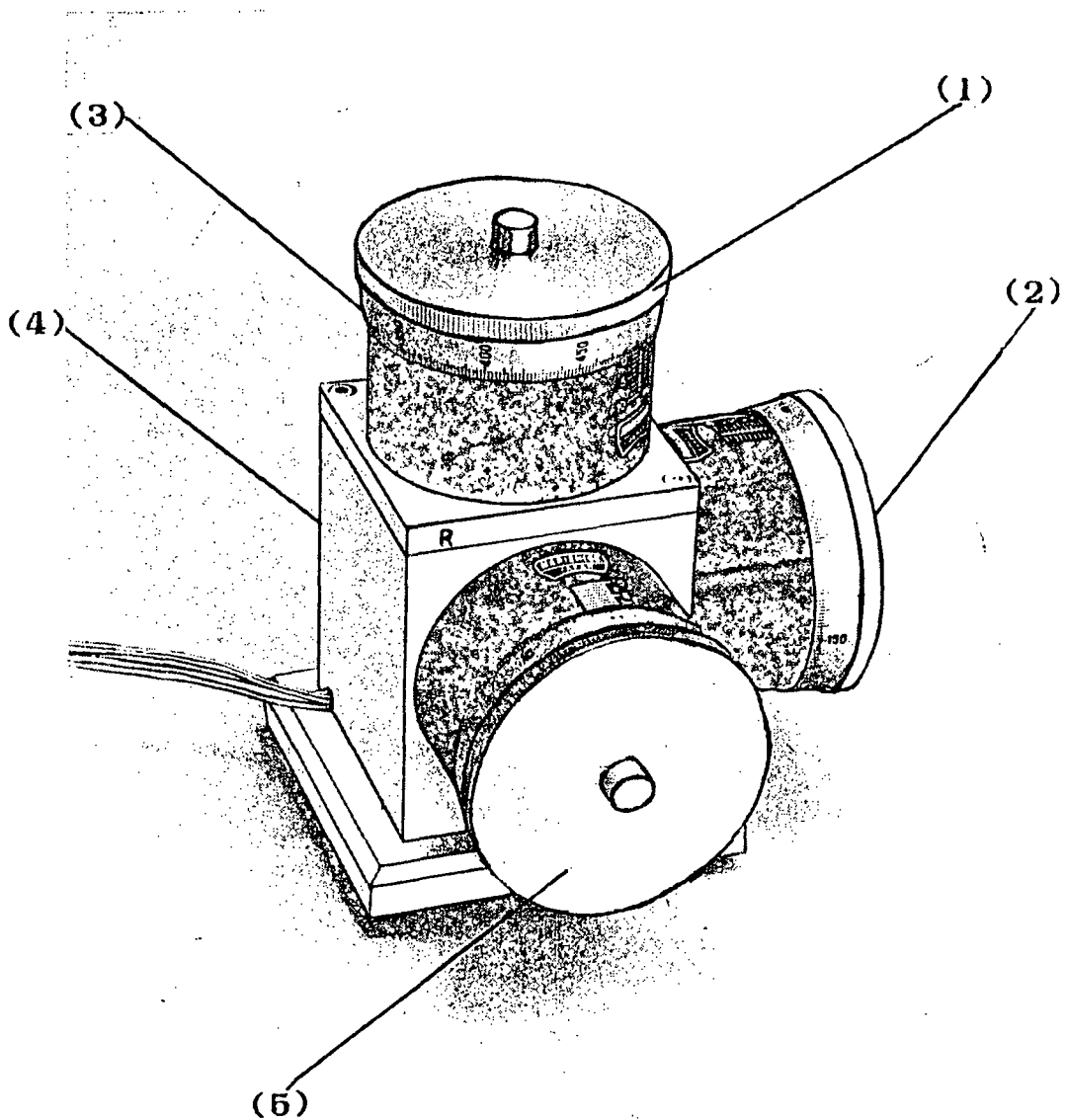

The Headstage

The headstage of the MO-203 is composed of three microdrive units which are assembled at right angles from each other, so as to represent X, Y and Z movements. A micropipette can be moved to any point within a 10mm sided cube by making use of hydraulic pressure which is directed from a remotely located controller.

The following parts are necessary when mounting the headstage to various microscopes.

- (1) Adaptor for type of Microscope (See catalog for applicable part number(s))
- (2) MN-2 (or MN-3) Coarse movement Manipulator

The headstage must be mounted so that the printed "R" is facing the user when Right hand use applies. In case of Left hand use, turn the headstage to the left 90 degrees so that the printed "L" is facing the user.

In order to connect the headstage with the coarse movement manipulator MN-2, you must screw the supplied connecting rod into the back of the headstage. When Right hand use applies, screw the connecting rod into the hole marked "R". For Left hand use, screw the connecting rod into the hole marked "L".

After mounting the headstage completely to the microscope, rotate the knobs of the Controller so as to make sure that each knob is controlling the correct axis.

The Controller

The Controller is made up of three operation knobs (1) (2) (5) which control independent movement along all three axes.

Working Distance

Headstage: X-axis

Y-axis

Z-axis

Fine Movement

Movable Distance 10mm each

Controller: X, Y and Z Direction

Fine Movement

Controllable Distance 10mm each

One rotation of the knob results in the movement of the microdrive by 500 microns, while the minimum scale of the control knob for X, Y and Z stands for 2 microns.

Accessories

| | | |
|--------------------|------|------|
| (1) Pipette Holder | H-7 | 1 ea |
| (2) Ball Joint | B-8C | 1 ea |

Handling and Maintenance of the Instrument

This precision instrument is delicate and should be handled with care. Avoid any shock to the instrument. Be aware that pulling on the hydraulic lines can result in damaging the sealed hydraulic system. Keep in mind that this system is sensitive to temperature change. To minimize unwanted movement of the headstage, keep MO-203 in a stable temperature environment away from drafts and sun.

After long term use, the oil may change color. This is due to oxidation of the oil. This change should not affect the instrument's performance.

After each use turn all three vernier controls to their zero positions in order to prevent excessive oil leakage through diaphragm. (A small amount of oil leakage is inevitable and should not be regarded as a defect in the device.)

For best results when operating the MO-203 each of the vernier controls should be at the mid-range of their 10mm travel.

Never attempt to disassemble a control cylinder. If so, this will make re-adjustment very difficult.

The oil containers of the microdrives and controller are of a cartridge design so that repair is a matter of replacing the cartridge.

If problems occur with the system, please do not attempt to repair, but rather contact us and we will repair it for you.

David Kleinfeld
Room 6H-424
ATT Bell Laboratories
600 Mountain Avenue
Murray Hill, N.J. 07974

INSTRUCTIONS

MN - 2

NARISHIGE CO., LTD.

27-9, MINAMIKARASUYAMA 4-CHOME, SETAGAYA-KU, TOKYO, JAPAN.

TEL: (03)308-8383 CABLE: NARISHIGELABO

FACSIMILE: (03)308-8700



株式会社

ナリシゲ

〒157 東京都世田谷区南烏山4丁目27番9号
TEL.(03)308-8383 FAX.(03)308-8700

I n s t r u c t i o n M a n u a l
f o r
M N - 2 (M N - 3) T h r e e D i m e n s i o n a l
M a n i p u l a t o r

Thank you for purchasing the Narishige MN-2/MN-3 Micromanipulator. The MN-2/MN-3 has been built with pride and should give you years of trouble-free operation. This manual is designed to help you get maximum performance from your MN-2/MN-3. If after reading it you require further assistance, please never hesitate to call us directly to speak with one of our applications specialists.

Unpacking

The MN-2/MN-3 has been carefully packed and inspected. Should any of the parts arrive in a damaged condition, contact your common carrier immediately. Do not call us since corrective action must start with the carrier. Be assured that we will cooperate completely to help correct the problem and to have you operational quickly.

M N - 2 (M N - 3) T h r e e D i m e n s i o n a l M a n i p u l a t o r

This manipulator is generally combined with the headstage of MO-202, MO-203 or MO-204 Micromanipulators for coarse positioning a micropipette. This manipulator can be mounted onto a microscope directly by using one of the Narishige Co. manufactured mounting adaptors. MN-2 is designed to be mounted on the condensor mounting attachments, while the MN-3 is designed to be mounted on microscope stage mounting adaptors.

The MN-2 uses a P-2 mounting attachment and the MN-3 uses a P-3 mounting attachment, which is available for height adjustment.

The Principal Parts

MN-2

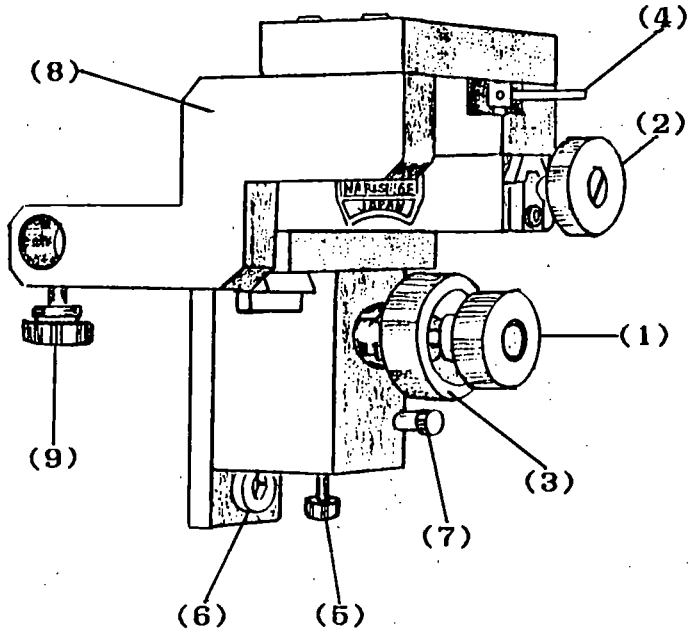

- (1) Operation Knob for Z-Axis
- (2) Operation Knob for X-Axis
- (3) Operation Knob for Y-Axis
- (4) Locking Lever for X
- (5) Locking Screw for Y

- (6) Fixing hole for Mounting Adaptor
- (7) Locking Screw for Z
- (8) P-2 (P-3)
- (9) Fixing Screw for Headstage

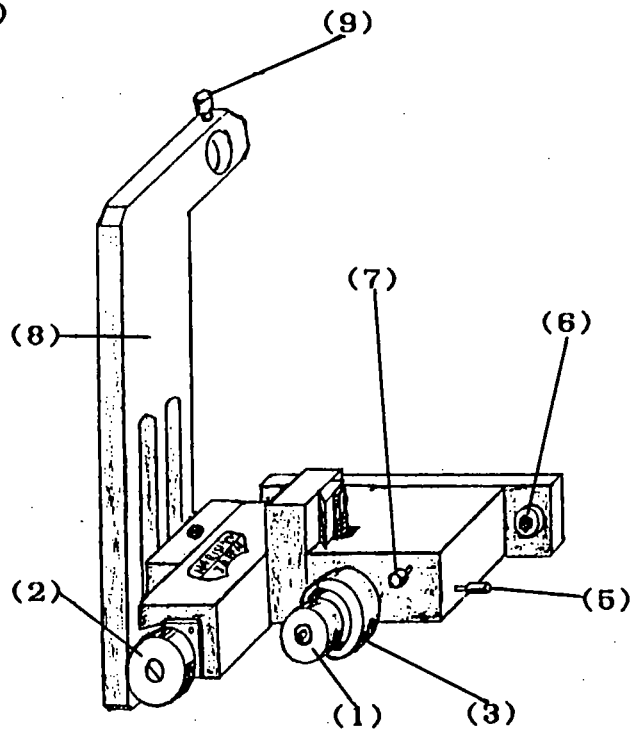

Working Distance

| | | |
|----------------|------|-----------------|
| 1. X-direction | 30mm | Coarse Movement |
| 2. Y-direction | 30mm | Coarse Movement |
| 3. Z-direction | 25mm | Coarse Movement |

Features of the MN-2/MN-3

- A. The main body is made of duraluminum and designed to be compact, lightweight and sturdy.
- B. Can be mounted on almost any microscope by making use of microscope mounting adaptors available from Narishige Co. Ltd.
- C. Locking levers for X, Y and Z directions are included for fixing the manipulator in any position.

Accessories

| | | |
|------|-----|---------------|
| MN-2 | P-2 | 1 ea included |
| MN-3 | P-3 | 1 ea included |

Maintenance Notice

This manipulator has been adjusted at our factory for precise operation and no field adjustments should be required.

When handling, please observe the following:

1. Avoid any shock to the instrument.
2. Do not take the instrument apart.
3. Do not expose the instrument to dust, blood, chemicals, or direct rays of sun.

Should any problem arise, please contact Narishige USA for a fast, courteous assessment of your need.

NARISHIGE USA, INC.'S ONE YEAR LIMITED WARRANTY

Narishige USA, Inc. (NUSA) warrants purchased equipment (except as noted below) to be free of defects in material and workmanship under normal use and maintenance from the date of shipment for a period of one year. In the case of (i) fuses, lamps, light emitting diodes, and LCD's, and (ii) separately purchased replacement parts, the warranty period is 90 days. Consumable supplies, heating elements, and cables are warranted to be free of defects in material and workmanship at the time of shipment. Labor invoiced in connection with repairs performed at NUSA's facility is warranted for a period of 90 days from the date of shipment of the repaired equipment.

All warranties herein extend to the original end user only and are not assignable or transferable.

All warranties herein shall not apply to any damage or defect which is caused by or due, directly or indirectly, to misuse, abuse, negligence, accident, unauthorized repair or repair parts.

ALL WARRANTIES IMPLIED BY LAW INCLUDING ANY WARRANTY OF MERCHANTABILITY OR FITNESS FOR A PARTICULAR PURPOSE ARE LIMITED TO THE DURATION OF THE EXPRESS WARRANTIES CONTAINED HEREIN. THE WARRANTIES HEREIN ARE EXPRESSLY IN LIEU OF ALL OTHER WARRANTIES. IN NO EVENT SHALL NUSA BE LIABLE FOR ANY INCIDENTAL OR CONSEQUENTIAL DAMAGES FOR THE BREACH OF ANY WARRANTY. NUSA'S LIABILITY SHALL BE LIMITED TO REPAIRING OR REPLACING, AT NUSA'S OPTION, ANY COMPONENT WHICH NUSA FINDS AT NUSA'S SITE TO BE DEFECTIVE IN MATERIAL OR WORKMANSHIP.

NO WARRANTIES, WHETHER EXPRESS OR IMPLIED, INCLUDING ANY WARRANTY OF MERCHANTABILITY OR FITNESS FOR A PARTICULAR PURPOSE ARE MADE BY ANY DISTRIBUTOR OR DEALER OF THIS PRODUCT AND IN NO EVENT SHALL ANY DISTRIBUTOR OR DEALER OF THIS PRODUCT BE LIABLE FOR THE PAYMENT OF ANY INCIDENTAL OR CONSEQUENTIAL DAMAGES OF ANY KIND WHATSOEVER.

In order to obtain warranty service, the original end user should return this product to Narishige USA, Warranty Dept., One Plaza Road, Greenvale, New York 11548, together with a brief description of the problem that is sought to be remedied. In returning this product, the original end user must repay all postage, shipping, transportation, insurance and delivery costs.

The return of the warranty registration form to NUSA will serve as a basis for establishing proof of purchase and proof of purchase date by the original end user. The failure of the original end user to return the warranty registration form will not affect the rights hereunder, so long as the original end user can establish proof of purchase and proof of purchase date.

DEAR CUSTOMER:

We are pleased to have you join the growing family of customers who have purchased from Narishige USA, Inc. (NUSA). We appreciate the confidence which you have placed in us. It is this confidence which keeps us striving to provide the highest quality and value in all of our products.

Narishige USA, Inc. offers a broad range of complimentary products, some of which are described in the accompanying literature. Please feel free to contact us if we can help you with any of these products, or if you require application assistance with your current purchase.

So that your warranty will be valid, it is important that you complete and return the "Warranty Registration" card.

NARISHIGE USA, INC.

ONE PLAZA ROAD • GREENVALE, NEW YORK 11548 • 516/621-4588

David Kleinfeld
Room 6H-424
ATT Bell Laboratories
600 Mountain Avenue
Murray Hill, N.J. 07974

INSTRUCTIONS

MN-2 (MN-3)



NARISHIGE CO., LTD.

27-9. MINAMIKARASUYAMA 4-CHOME, SETAGAYA-KU, TOKYO, JAPAN.

TEL: (03)308-8383 CABLE: NARISHIGELABO

FACSIMILE: (03)308-8700



株式
会社

ナリシゲ

〒157 東京都世田谷区南烏山4丁目27番9号
TEL.(03)308-8383 FAX.(03)308-8700

MO-203型 三次元油圧マイクロマニピュレーター 収納図

MO-203 3-dimensional Hydraulic Micromanipulator Package

取り付けバー (10mm) ... 駆動部本体にセットされています。

Fixing Bar attached to
the Head Stage

操作部
Controller

駆動部
Head Stage

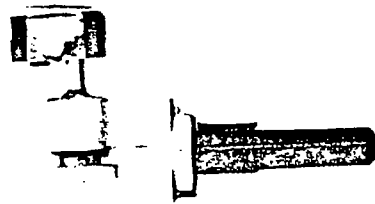

ボールジョイント (B-8C)
Ball Joint

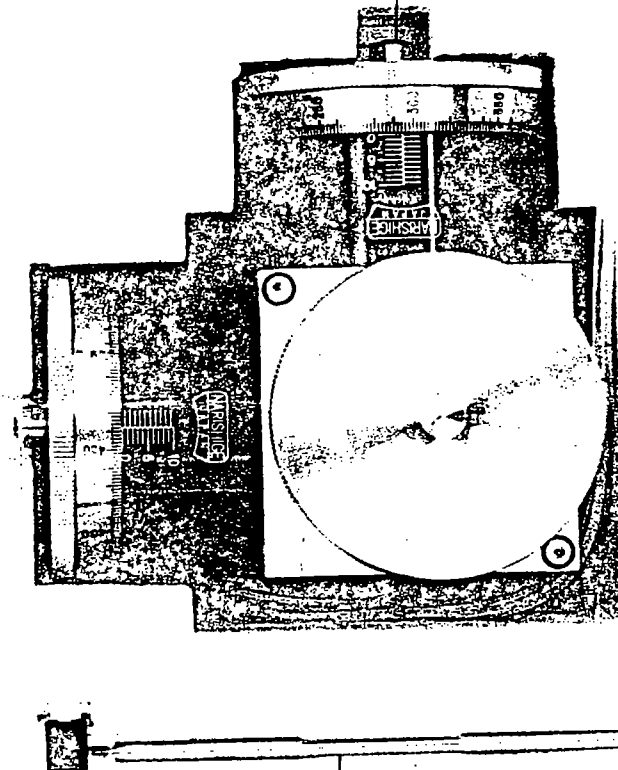

ピペットホルダー (H-7)
Pipette Holder

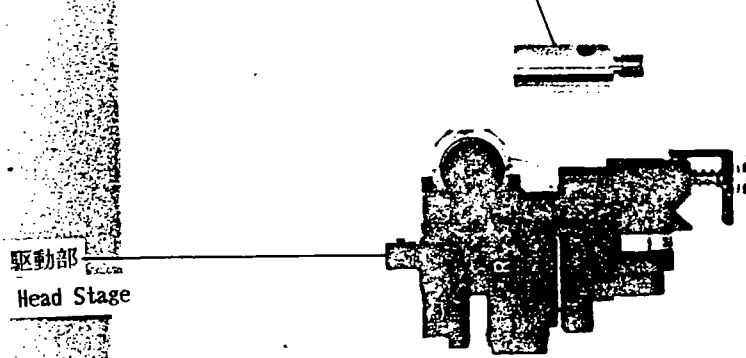

駆動部
Head Stage

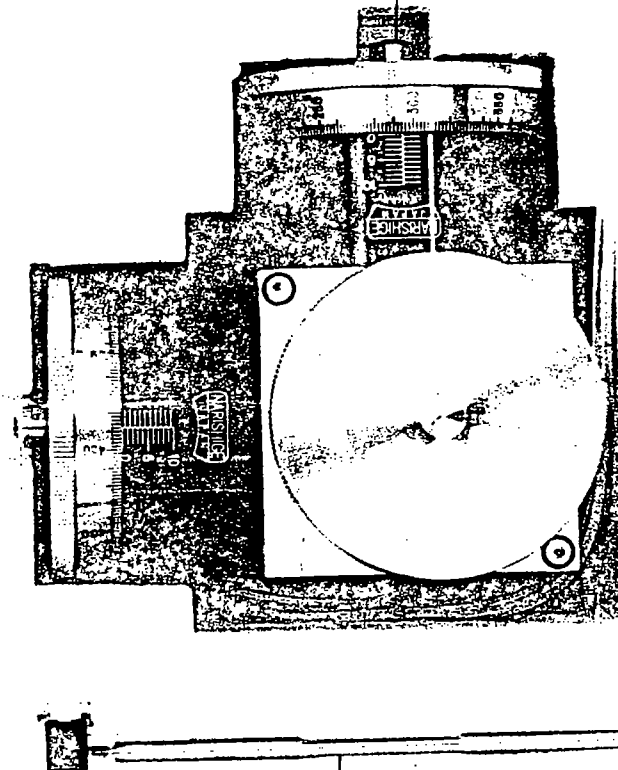

操作部
Controller

I n s t r u c t i o n M a n u a l
f o r
M N - 2 (M N - 3) T h r e e D i m e n s i o n a l
M a n i p u l a t o r

Thank you for purchasing the Narishige MN-2/MN-3 Micromanipulator. The MN-2/MN-3 has been built with pride and should give you years of trouble-free operation. This manual is designed to help you get maximum performance from your MN-2/MN-3. If after reading it you require further assistance, please never hesitate to call us directly to speak with one of our applications specialists.

Unpacking

The MN-2/MN-3 has been carefully packed and inspected. Should any of the parts arrive in a damaged condition, contact your common carrier immediately. Do not call us since corrective action must start with the carrier. Be assured that we will cooperate completely to help correct the problem and to have you operational quickly.

M N - 2 (M N - 3) T h r e e D i m e n s i o n a l M a n i p u l a t o r

This manipulator is generally combined with the headstage of MO-202, MO-203 or MO-204 Micromanipulators for coarse positioning a micropipette. This manipulator can be mounted onto a microscope directly by using one of the Narishige Co. manufactured mounting adaptors. MN-2 is designed to be mounted on the condensor mounting attachments, while the MN-3 is designed to be mounted on microscope stage mounting adaptors.

The MN-2 uses a P-2 mounting attachment and the MN-3 uses a P-3 mounting attachment, which is available for height adjustment.

The Principal Parts

MN-2

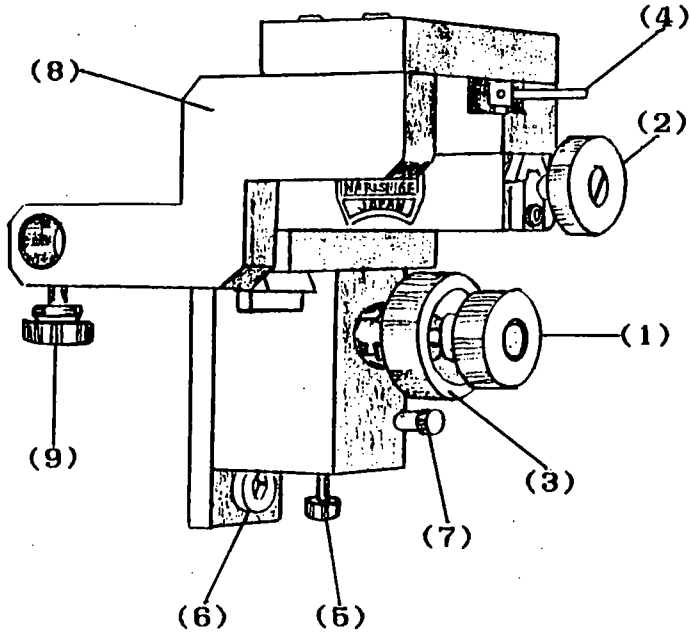

- (1) Operation Knob for Z-Axis
- (2) Operation Knob for X-Axis
- (3) Operation Knob for Y-Axis
- (4) Locking Lever for X
- (5) Locking Screw for Y

- (6) Fixing hole for Mounting Adaptor
- (7) Locking Screw for Z
- (8) P-2 (P-3)
- (9) Fixing Screw for Headstage

MN-3

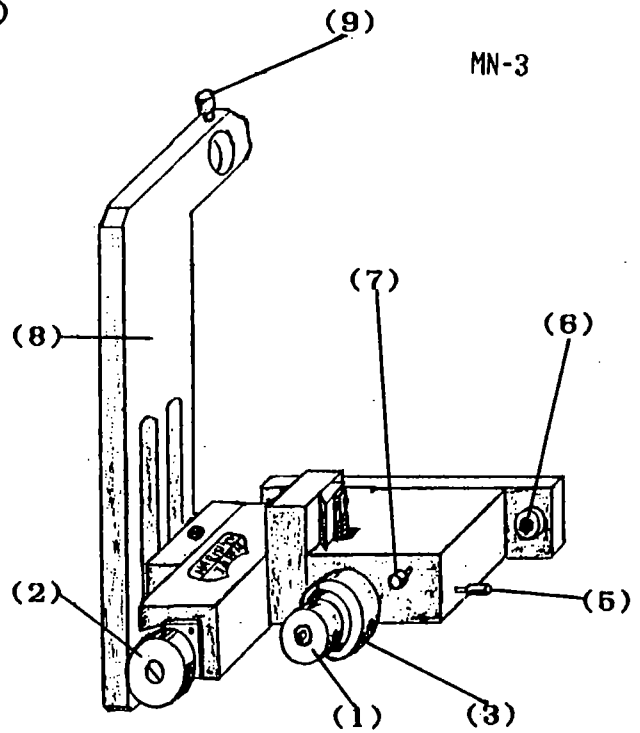

Working Distance

| | | |
|----------------|------|-----------------|
| 1. X-direction | 30mm | Coarse Movement |
| 2. Y-direction | 30mm | Coarse Movement |
| 3. Z-direction | 25mm | Coarse Movement |

Features of the MN-2/MN-3

- A. The main body is made of duralulminum and designed to be compact, lightweight and sturdy.
- B. Can be mounted on almost any microscope by making use of microscope mounting adaptors available from Narishige Co. Ltd.
- C. Locking levers for X, Y and Z directions are included for fixing the manipulator in any position.

Accessories

| | | |
|------|-----|---------------|
| MN-2 | P-2 | 1 ea included |
| MN-3 | P-3 | 1 ea included |

Maintenance Notice

This manipulator has been adjusted at our factory for precise operation and no field adjustments should be required.

When handling, please observe the following:

- 1. Avoid any shock to the instrument.
- 2. Do not take the instrument apart.
- 3. Do not expose the instrument to dust, blood, chemicals, or direct rays of sun.

Should any problem arise, please contact us for a fast, courteous assessment of your need.

PP-83 Glass Microelectrode Puller

Outline:

This microelectrode puller is designed to manufacture micropipettes for use in patch clamp experimentation. The tips of the electrodes produced by this puller can easily be fire polished so as to render them non-injurious to delicate cellular membranes even when tight (gigaohm) patch seals are made.

The pp-83 allows for the independent control of the two sequential pulls which are used to produce a patch pipette. The temperature of the filament during the first pull is controlled by the "first pull heat adjustment knob", and the length of the first pull can be controlled by the positioning of a microswitch. In addition to mechanically stopping the fall of the puller assembly, activation of the microswitch automatically turns off the heating filament. Prior to the second pull, the experimenter can reposition the heating element to the base of the narrowed portion of the glass capillary which was formed by the stretching of the molten glass during the first pull. After setting the "second pull heater adjustment knob", the second pull may be started. A patch micropipette is produced when the weight of the puller causes the molten glass to separate into two separate pieces.

Once the optimal heater adjustment settings have been determined, the consistent performance of the two independent heating circuits makes readjustment of the knobs unnecessary. The movable microforge feature of the PP-83 precludes the troublesome repositioning of the delicate capillary after the first pull.

Specifications:

| | |
|-----------------|---|
| Power Source: | 117 - 120 VOLT AC, (220 - 240 VOLTS AC) |
| Heater Voltage: | 1.5 VOLTS |
| Current: | 17A |
| Weight: | 6.6 Kgs. |
| Dimensions: | W180mm x D180 mm x H190 mm |

PP-83 GLASS MICROELECTRODE PULLER NAMES

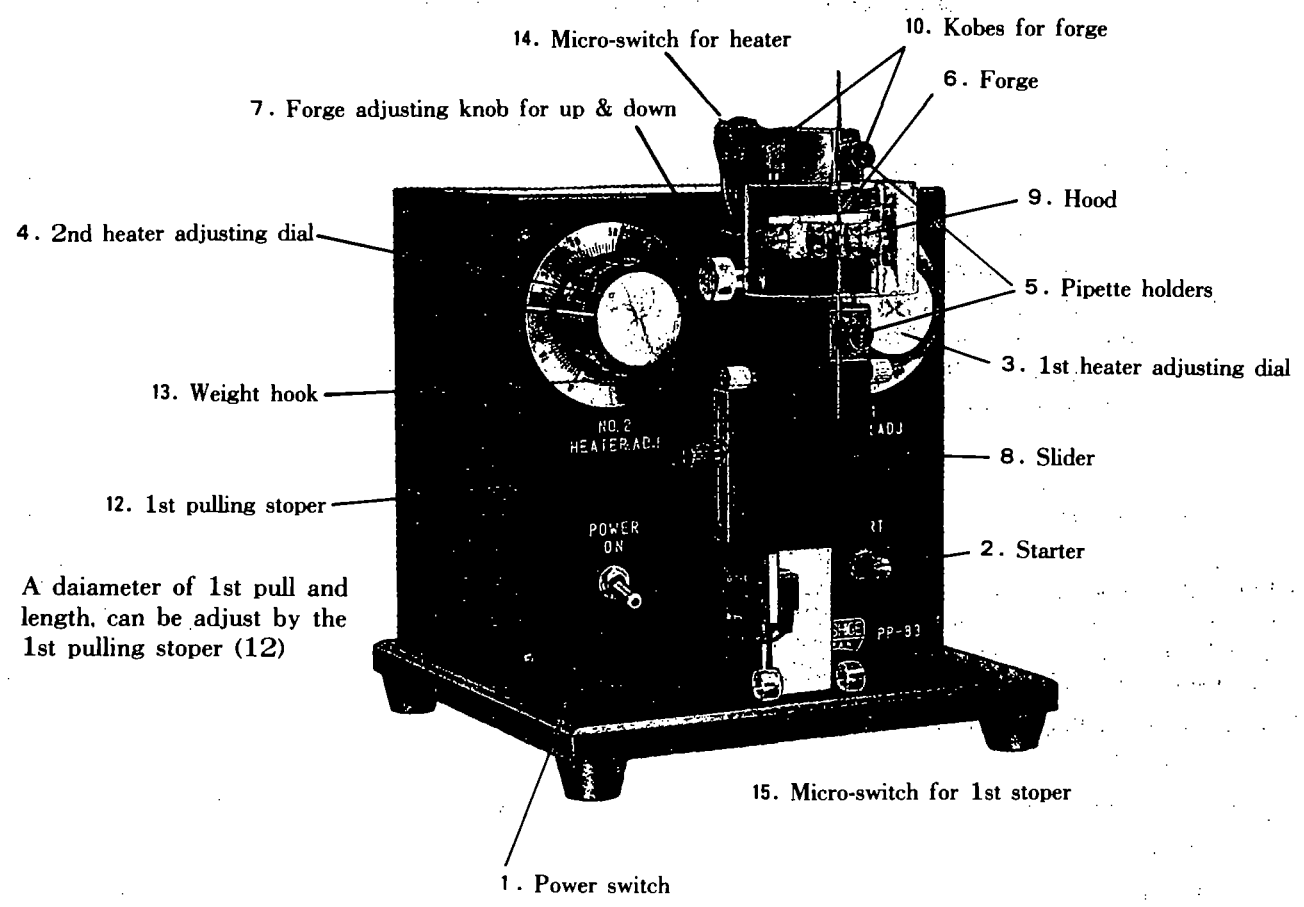

A diameter of 1st pull and length, can be adjust by the 1st pulling stoper (12)

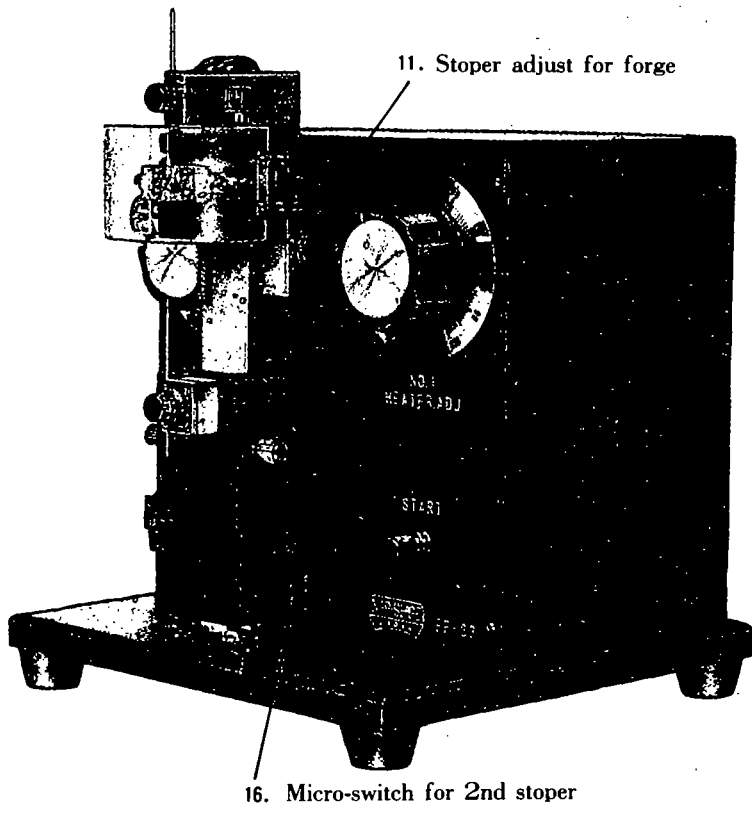

This stoper can be adjust length of 2nd pulling. The position is around 3/5 better.

PP-83 GLASS MICROELECTRODE PULLER

Make sure following points before you start

- * You will loosen the pipette holder knobs (5), take out a tool.
- * Check the heater adjusting dials (3) and (4) are indicating 0.
- * Check the forge part contact to the micro-switch (14) if not, adjust by the adjusting knob (7).
- * This puller's voltage operated for AC-100 volts, therefore use attached adaptor.

*** INSTRUCTION ***

- 1) Put a glass tube, hold above side tube only with (5) then the slider (8) moves up till stop it. Fix the tube below side by pipette holder (5).
- 2) Adjust the 1st pulling length "L" by stoper (12), set the micro-switch (15).
- 3) Turn on the power switch (1).
- 4) Cover the hood for forge (6).
- 5) Push the starter (2).
- 6) Turning right the 1st heater adjusting dial (3) mark around ~~38-42~~ for use PLATINUM ELEMENT. If use CANTAL WIRE mark around ~~58~~ *52-56*.

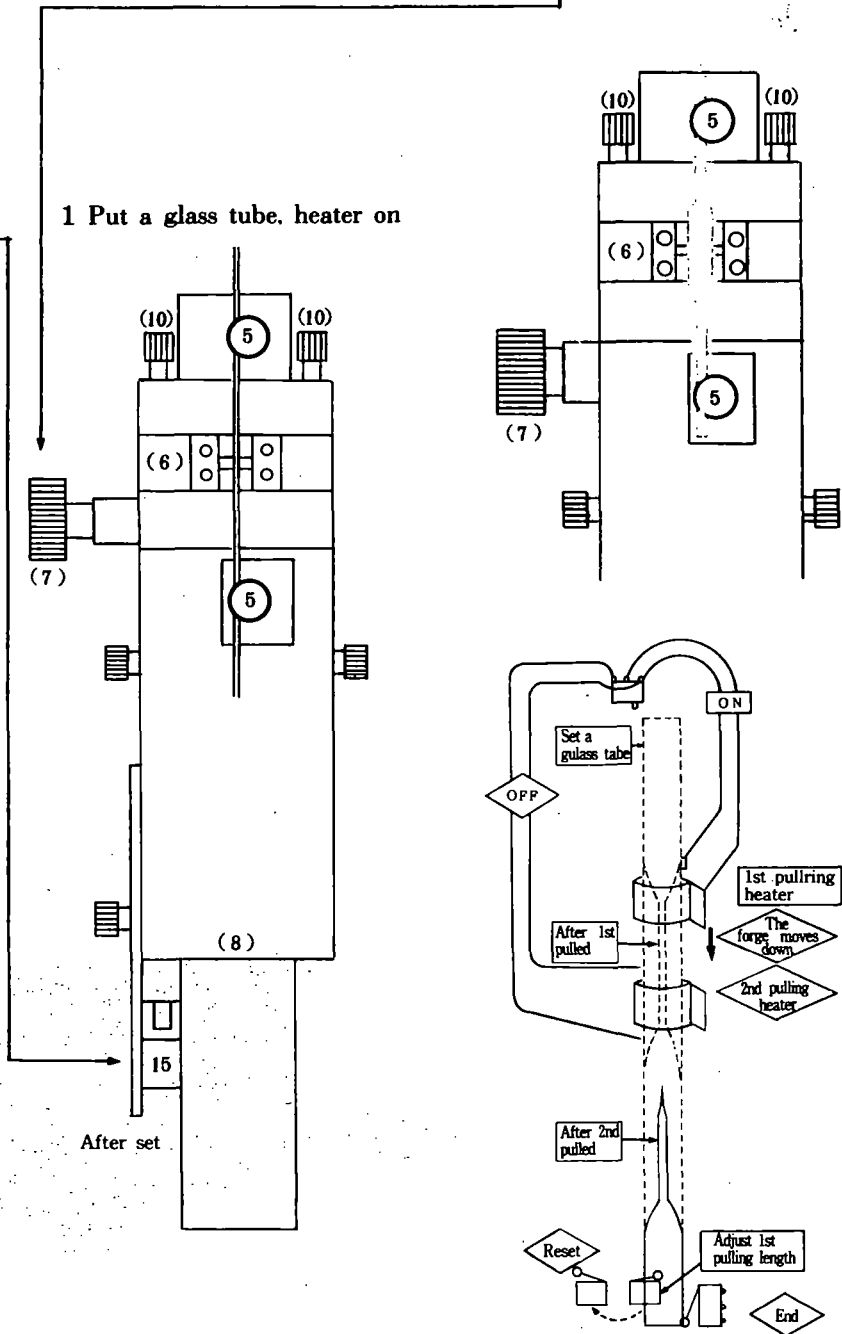

2 1st step pulled slider moves down to stoper

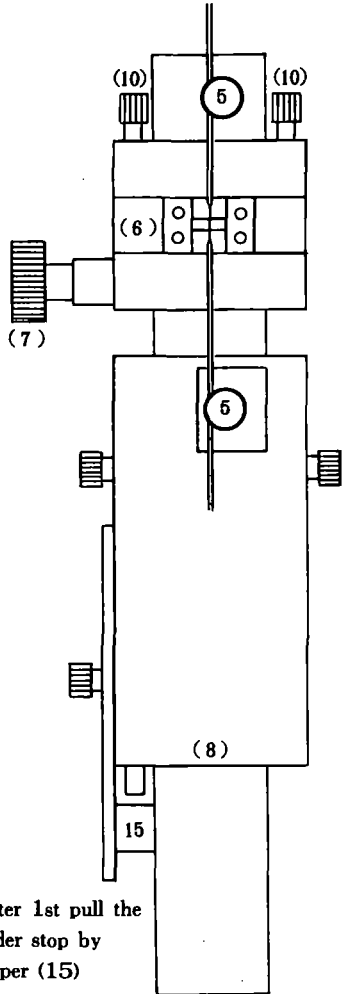

After 1st pull the slider stop by stoper (15)

7) The slider (8) moves down to 1st stoper (12).

3 Turning down the heater middle of pipette turn left micro-switch (15) Stater on (2)

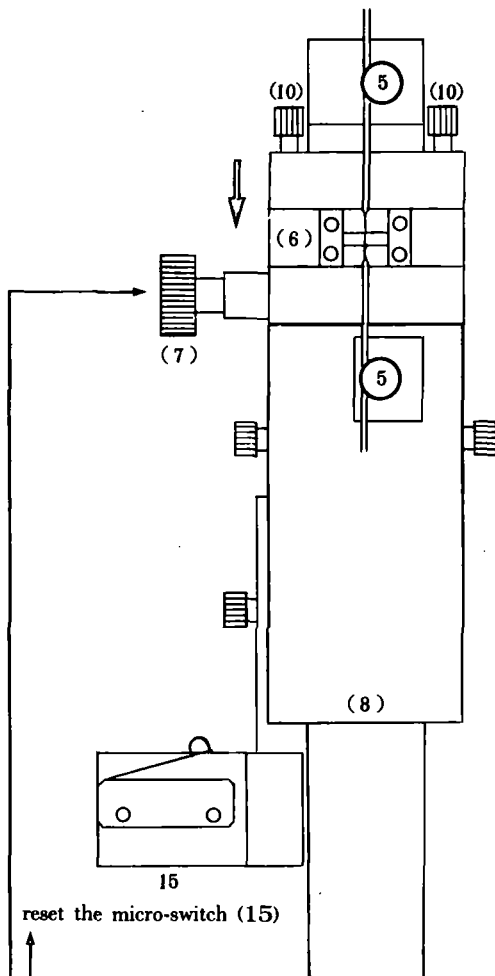

reset the micro-switch (15)

8) Turning down the heater (6) by the forge adjust knob (7), set the forge stoper by adjust knob (11).

9) Turn left the micro-switch (15) for reset.

10) Push the starter (2) again.

11) Turning right the 2nd heater adjusting dial (4) mark around 28-30 for use PLATINUM ELEMENT. If use CANTAL WIRE mark around 41. ~39.

~~11) Turning right the 2nd heater adjusting dial (4) mark around 28-30 for use PLATINUM ELEMENT. If use CANTAL WIRE mark around 41.~~

4 After 2nd pulled

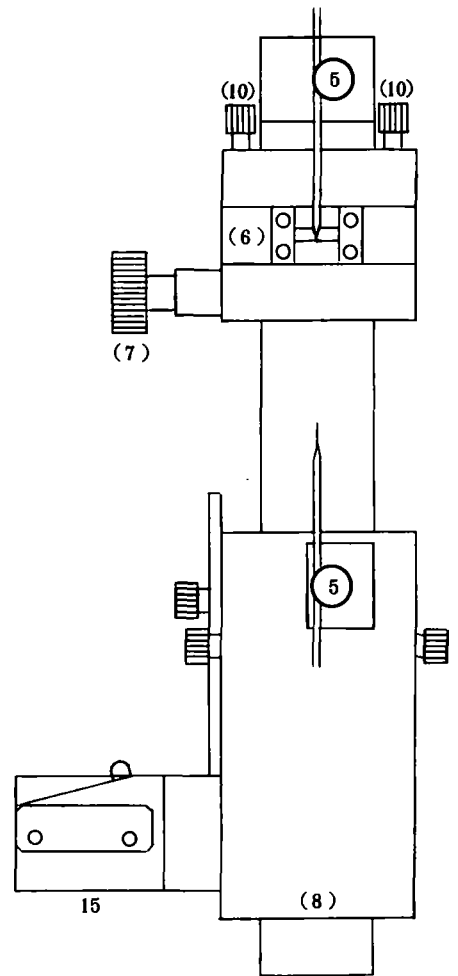

12) The slider (8) moves down.

How to adjust the forge position

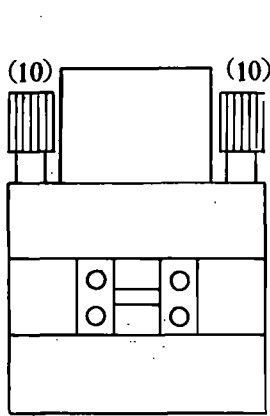

Loosen the knobs (10)

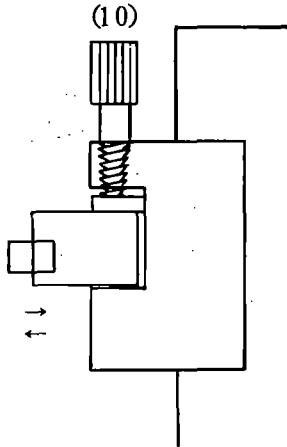

and adjust front back.

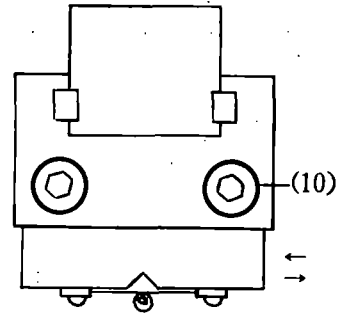

Also, left and right

How to adjust a diameter

A diameter of 1st pull and length, can be adjust by the 1st pulling stoper (12)

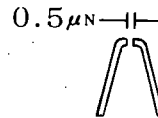
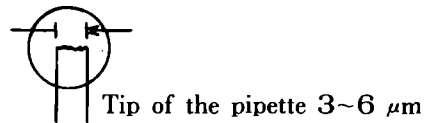
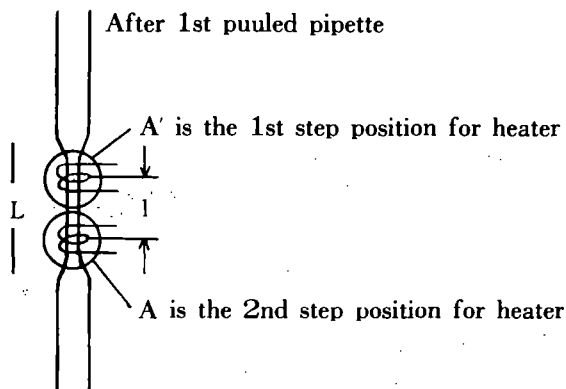

L is length of 1st pulled pipette
l is length of the heater moved down

Before start 2nd pull, wait 30/sec and the micro-switch (15) turn left to reset.

After heat-polish by micro-forge

The Names of the Principal Parts:

- (1) Power switch
- (2) Start button
- (3) 1st. heater adjustment dial(for the first pull)
- (4) 2nd. heater adjustment dial(for the second pull)
- (5) Pipette holders
- (6) Forge
- (7) Forge adjustment knob(for vertical adjustment)
- (8) Slider
- (9) Hood
- (10) Forge alignment set screws
- (11) Stopper for the second pull
- (12) Stopper for the first pull
- (13) Weight attachment hook
- (14) Microswitch to initiate the first pull
- (15) Microswitch to terminate the first pull
- (16) Microswitch to terminate the second pull

Notice:

Prior to operation, make sure the following items.

- (1) Confirm that the heater adjustment dials (3)(4) indicate "0".
- (2) Bring the forge mounting into contact with the forge microswitch(14) by turning the forge adjustment knob(7).
- (3) Apply the specific adaptor in case that the electric source is AC117 VOLTS, 220 VOLTS or 240 VOLTS, as this instrument is designed to operate under the voltage of AC 100 VOLTS.

Operation:

- (1) Insert a glass capillary through the filament and lock it in place by tightening the upper pipette holder(5). Move the slider(8) all the way up and fasten it in place by securing the capillary in the lower pipette holder(5).
- (2) As the first pull is terminated when the microswitch(15) is contacted by the base of the descending slider(8), the length and the diameter of the narrowed portion of the capillary which results from the first pull can be adjusted by varying the position of the microswitch(15). This is accomplished by sliding the microswitch assembly and fixing it in place by tightening the first pull stopper(12).
- (3) After adjusting the microswitch to the position which gives electrodes the desired shape, make sure, before initiating the first pull, that the microswitch(15) is set by swinging into the path of the slider.
- (4) Turn the power switch(1) to the ON position.
- (5) Close the forge hood(9).
- (6) Push the starter button(2).
- (7) Turn the first pull heater adjustment dial(3) clockwise to the setting. We recommend settings of 54 -56 for cantal filaments.
- (8) The heated portion of the capillary become molten and the descending slider is halted at the position of the stopper, activating the microswitch(15) simultaneously.
- (9) Following the completion of the first pull, move the forge(6) into the position for the second pull by turning the forge's adjustment knob. Mark this position for subsequent second pulls with the stopper for the second pull.
- (10) Swing the microswitch(15) out of the path of the slider(8).
- (11) 30 seconds after the first pull has been completed, you may begin the second pull Push the starter button(2) again.
- (12) Turn the heater adjustment dial for the second pull(4) clockwise until the proper settings is reached. We recommend settings of 39 - 41 for cantal filament.
- (13) The molten glass is caused to separate into two separate pieces by the downward movement of the slider.
- (14) After the second pull is completed, remove the two pieces of capillary tubing from the pipette holder(5).
- (15) The capillary tube in the lower pipette holder can now be heat polished to yield a "patch clamp" microelectrode.
- (16) Turn the forge adjustment knob(7) so that the forge mounting returns its uppermost position in contact with the forge microswitch(14).
- (17) Return the microswitch(15) to the original position.

Accessories:

| | | | |
|-----|-------------------------------|-----|----|
| (1) | Cantal filament | 2 | ea |
| (2) | Hexagonal wrench | 1 | ea |
| (3) | Set screw for fixing filament | 4 | ea |
| (4) | Fuse 1A | 2 | ea |
| (5) | Forge | 1 | ea |
| (6) | Glass capillary | 100 | ea |

Schematic Representation of the First and Second Pulls

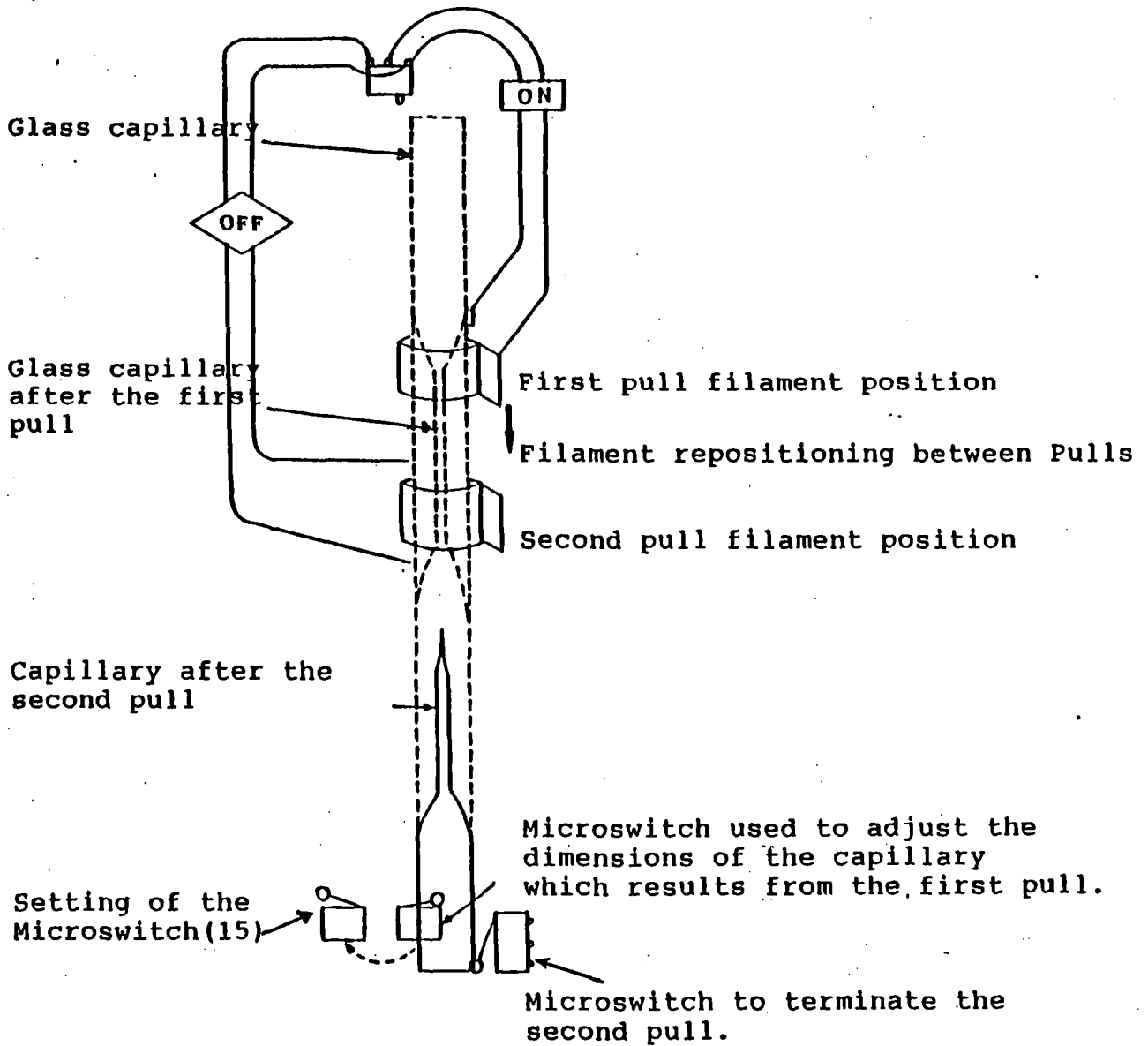

June, 1985

PP-83 Glass Microelectrode Puller

Actual Data of Manufacturing the Electrodes for
"Patch Clamp" and "Holding Pipette"

1. First heater adjusting dial (voltage adjustment) set at 65.

| Second heater adjusting dial (voltage adjustment) | Time | Diameter of the Tip |
|---|-------------------|---------------------|
| Scale 35 | 14 sec. | 1.2 micron |
| 34 | 15 " | 2.4 " |
| 33 | 16 " | 10.0 " |
| 32 | 28 " | 18.0 " |
| 31 | 40 " | 19.0 " |
| 30 | 4 Min. 30 Sec. | 28.0 " |

2. The diameter of the electrode tip may vary from above figures according to the time interval of the first pull and the second pull. Attention must be paid not to remove the microswitch (stopper) before the heater gets cool, otherwise the melted capillary may be extended further by remaining heat.

3. Above data may also change due to the stroke of the first pull.

4. Above data has been derived from the setting of the first pull voltage at 65 scale. The consequences may vary according to the first pull voltage.

5. As the diameter of the electrode may change due to the difference of the instrument itself, so please make use of the above data as a standard in case of making the electrodes.

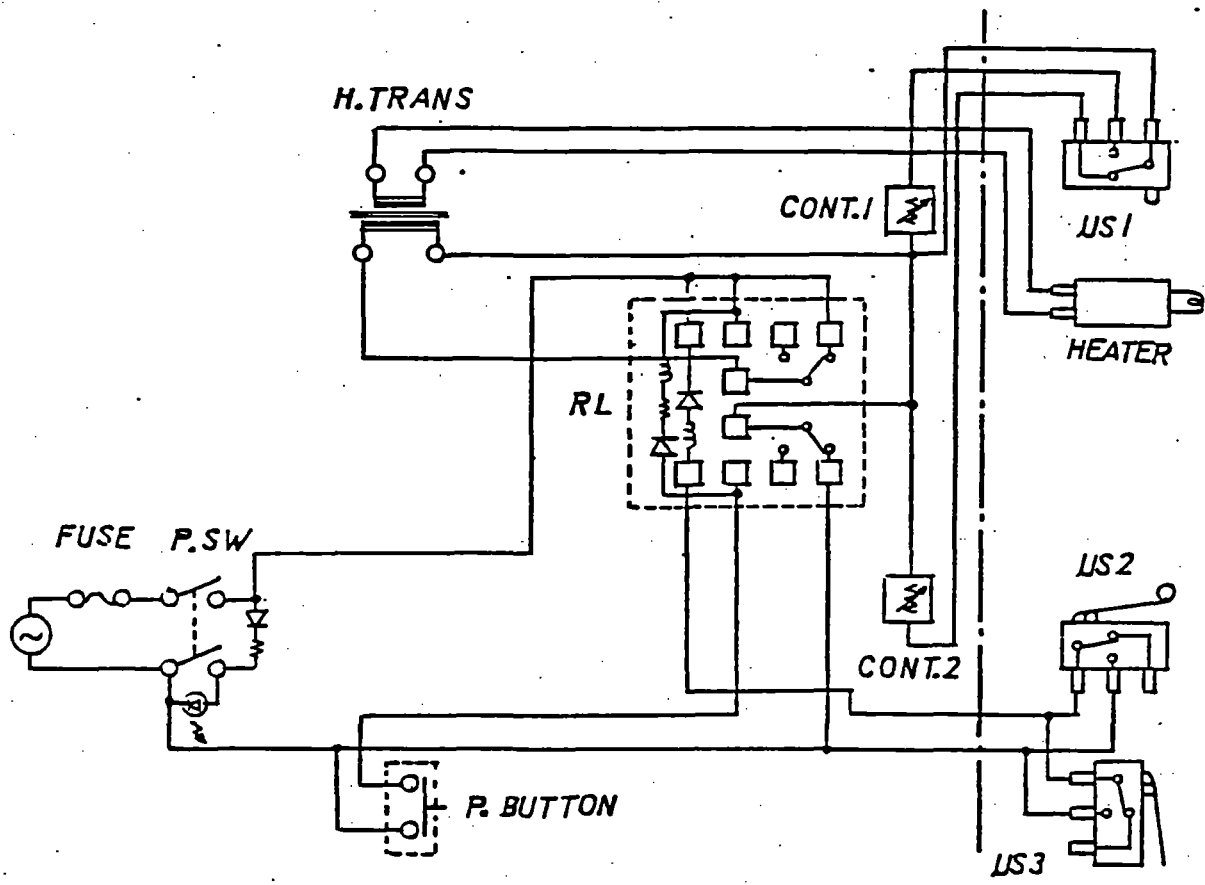

PP-83

NARISHIGE USA, INC.'S ONE YEAR LIMITED WARRANTY

Narishige USA, Inc. (NUSA) warrants purchased equipment (except as noted below) to be free of defects in material and workmanship under normal use and maintenance from the date of shipment for a period of one year. In the case of (i) fuses, lamps, light emitting diodes, and LCD's, and (ii) separately purchased replacement parts, the warranty period is 90 days. Consumable supplies, heating elements, and cables are warranted to be free of defects in material and workmanship at the time of shipment. Labor invoiced in connection with repairs performed at NUSA's facility is warranted for a period of 90 days from the date of shipment of the repaired equipment.

All warranties herein extend to the original end user only and are not assignable or transferable.

All warranties herein shall not apply to any damage or defect which is caused by or due, directly or indirectly, to misuse, abuse, negligence, accident, unauthorized repair or repair parts.

ALL WARRANTIES IMPLIED BY LAW INCLUDING ANY WARRANTY OF MERCHANTABILITY OR FITNESS FOR A PARTICULAR PURPOSE ARE LIMITED TO THE DURATION OF THE EXPRESS WARRANTIES CONTAINED HEREIN. THE WARRANTIES HEREIN ARE EXPRESSLY IN LIEU OF ALL OTHER WARRANTIES. IN NO EVENT SHALL NUSA BE LIABLE FOR ANY INCIDENTAL OR CONSEQUENTIAL DAMAGES FOR THE BREACH OF ANY WARRANTY. NUSA'S LIABILITY SHALL BE LIMITED TO REPAIRING OR REPLACING, AT NUSA'S OPTION, ANY COMPONENT WHICH NUSA FINDS AT NUSA'S SITE TO BE DEFECTIVE IN MATERIAL OR WORKMANSHIP.

NO WARRANTIES, WHETHER EXPRESS OR IMPLIED, INCLUDING ANY WARRANTY OF MERCHANTABILITY OR FITNESS FOR A PARTICULAR PURPOSE ARE MADE BY ANY DISTRIBUTOR OR DEALER OF THIS PRODUCT AND IN NO EVENT SHALL ANY DISTRIBUTOR OR DEALER OF THIS PRODUCT BE LIABLE FOR THE PAYMENT OF ANY INCIDENTAL OR CONSEQUENTIAL DAMAGES OF ANY KIND WHATSOEVER.

In order to obtain warranty service, the original end user should return this product to Narishige USA, Warranty Dept., One Plaza Road, Greenvale, New York 11548, together with a brief description of the problem that is sought to be remedied. In returning this product, the original end user must repay all postage, shipping, transportation, insurance and delivery costs.

The return of the warranty registration form to NUSA will serve as a basis for establishing proof of purchase and proof of purchase date by the original end user. The failure of the original end user to return the warranty registration form will not affect the rights hereunder, so long as the original end user can establish proof of purchase and proof of purchase date.

WARRANTY REGISTRATION

Dealer (if applicable) _____ Product Purchased _____

Serial No. _____

Invoice No. _____

Date of Delivery _____

Organization Name _____

Address _____

City _____

State _____

Zip _____

Country _____

Individual Name _____

In order to insure proper warranty service, user must fill out and return warranty registration form within 15 days. Detach, fold, and return self-addressed card.

NARISHIGE USA, INC.
One Plaza Road
Greenvale, NY 11548
U.S.A.

PLACE
STAMP
HERE

DEAR CUSTOMER:

We are pleased to have you join the growing family of customers who have purchased from Narishige USA, Inc. (NUSA). We appreciate the confidence which you have placed in us. It is this confidence which keeps us striving to provide the highest quality and value in all of our products.

Narishige USA, Inc. offers a broad range of complimentary products, some of which are described in the accompanying literature. Please feel free to contact us if we can help you with any of these products, or if you require application assistance with your current purchase.

So that your warranty will be valid, it is important that you complete and return the "Warranty Registration" card.

NARISHIGE USA, INC.

ONE PLAZA ROAD • GREENVALE, NEW YORK 11548 • 516/621-4588

Instruction Manual
for
MO-203 Three Dimensional Hydraulic
Micromanipulator

Thank you for purchasing the Narishige MO-203 Hydraulic Micromanipulator. The MO-203 has been built with pride and should give you years of trouble-free operation. This manual is designed to help you get maximum performance from your MO-203. If after reading it you require further assistance, please never hesitate to call us directly to speak with one of our applications specialists.

Unpacking

The MO-203 has been carefully packed and inspected, a picture of the package contents is shown below. You should have one (1) of each of the items shown. Should any of the parts arrive in a damaged condition, contact your common carrier immediately. Do not call us since corrective action must start with the carrier. Be assured that we will cooperate completely to help correct the problem and to have you operational quickly.

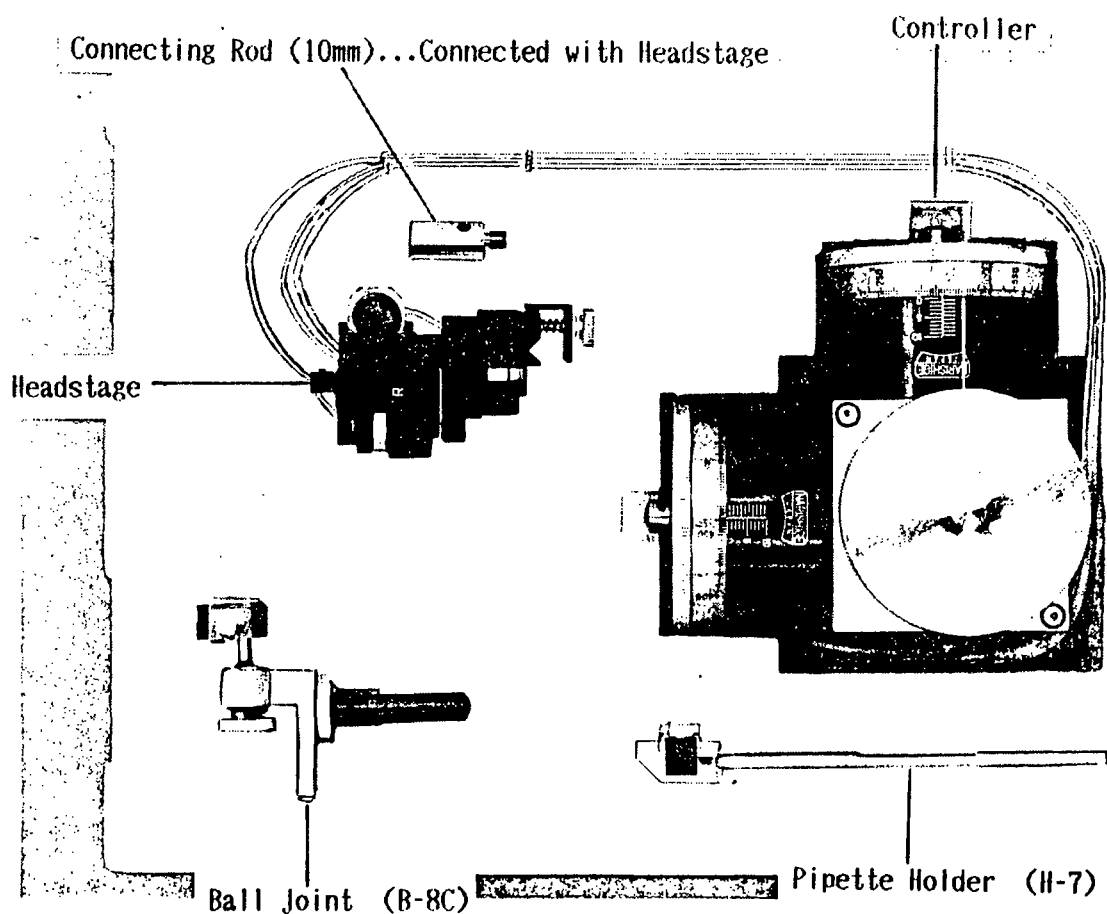

The MO-203 is a compact, vibration-free, three dimensional hydraulic micromanipulator. Smooth microdrive movement through a 10mm range is remotely and independently controlled for each of the X, Y and Z axes. The smooth vibration-free movement of the microdrive makes the MO-203 ideal for inserting microelectrodes into small cells or culture.

This manipulator is light-weight and is designed to be mounted on a microscope using specific adaptors which enhance the vibration-free movement.

This MO-203 manipulator is designed for both Right hand and Left hand use. Adjust both the headstage and controller so that the printed "R" is facing the user when Right hand use applies. Do the same for Left hand use while making sure that the printed "L" is facing the user.

In order to connect the headstage with the coarse movement manipulator (MN-2), you should screw the connecting rod into the back of the headstage. In case of Right hand use, the connecting rod should be screwed into the hole indicated "R". In case of left hand use, screw the connecting rod into the hole indicated "L".

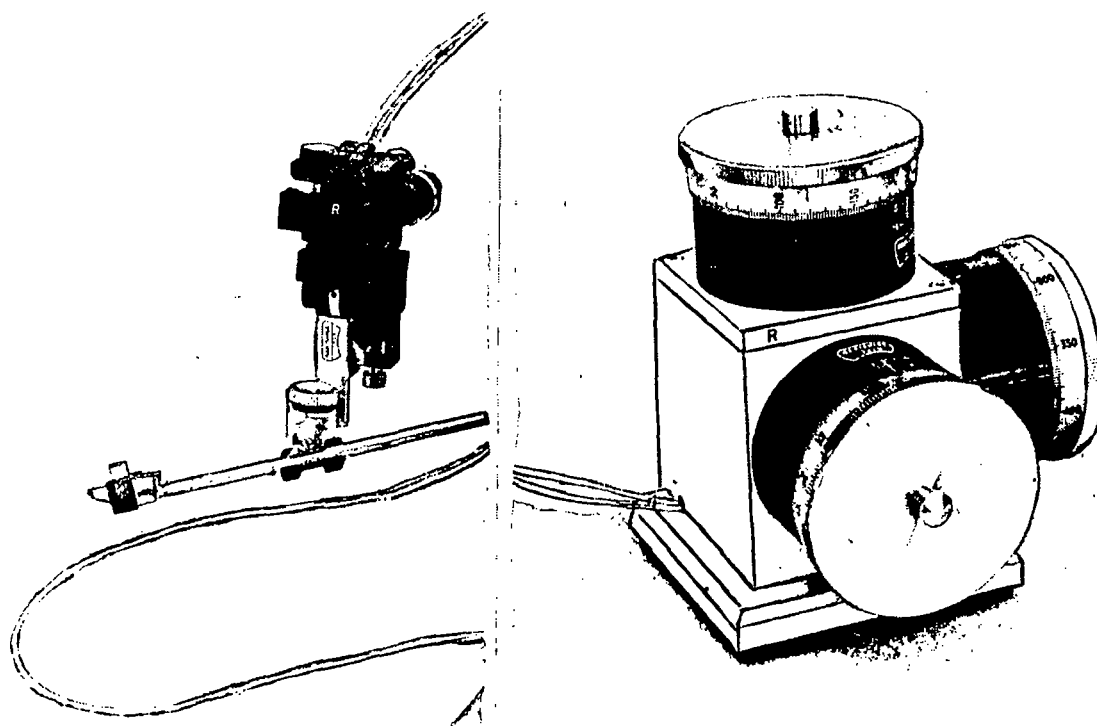

Principal Parts of the Headstage

When the headstage is positioned to face "R" in front, you can use it for Right hand use. When positioning to face "L" in front, you can use it for Left hand use.

Right Hand Use

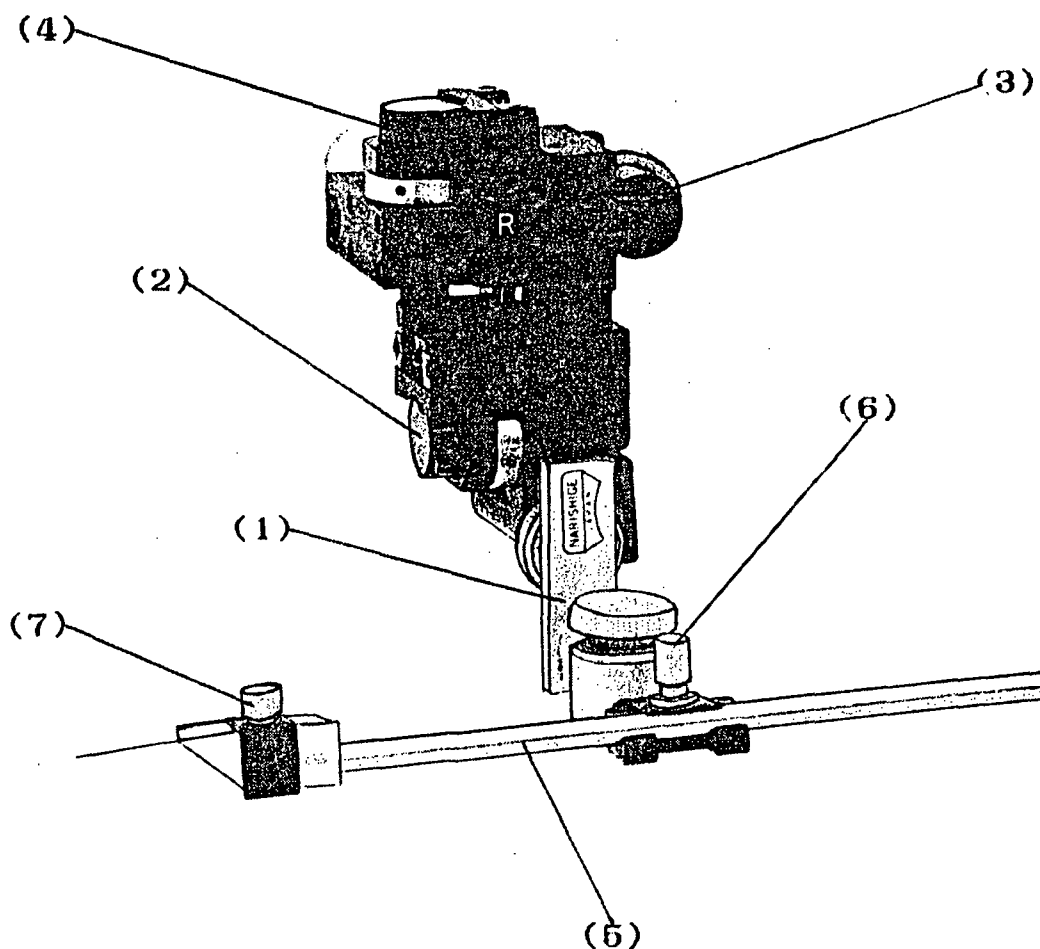

- (1) Ball Joint B-8C
- (2) X-unit for Right hand use, Y-unit for Left hand use
- (3) Y-unit for Right hand use, X-unit for Left hand use
- (4) Z-unit
- (5) Pipette Holder H-7
- (6) Pipette Holder Fixing Screw
- (7) Pipette Fixing Screw

Principal Parts of the Controller

- (1) Z-axis Control Knob
- (2) X-axis Control Knob for Right hand use
Y-axis Control Knob for Left hand use
- (3) Operation Scale
- (4) Controller Housing
- (5) Y-axis Control Knob for Right hand use
X-axis Control Knob for Left hand use

Right Hand Use

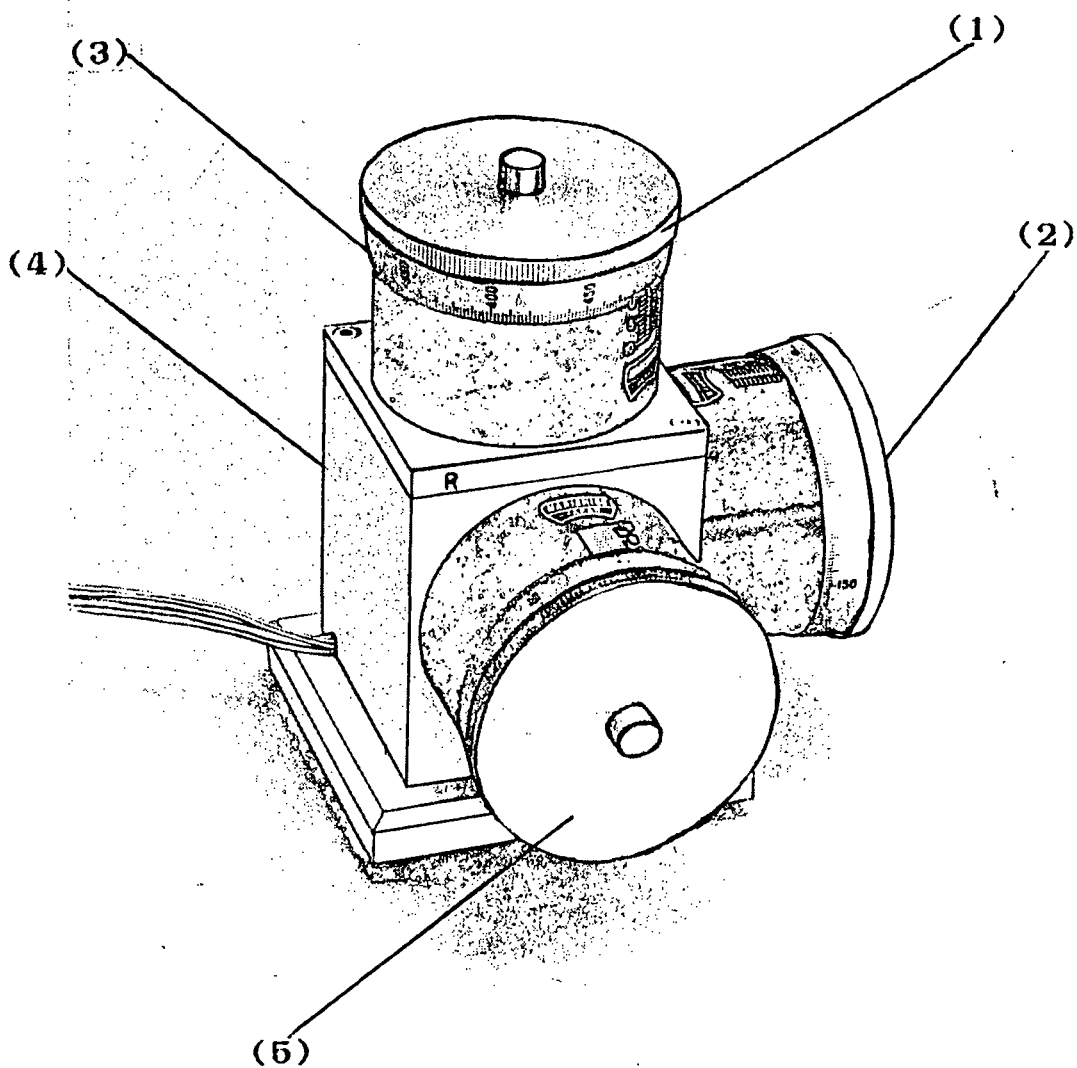

The Headstage

The headstage of the MO-203 is composed of three microdrive units which are assembled at right angles from each other, so as to represent X, Y and Z movements. A micropipette can be moved to any point within a 10mm sided cube by making use of hydraulic pressure which is directed from a remotely located controller.

The following parts are necessary when mounting the headstage to various microscopes.

- (1) Adaptor for type of Microscope (See catalog for applicable part number(s))
- (2) MN-2 (or MN-3) Coarse movement Manipulator

The headstage must be mounted so that the printed "R" is facing the user when Right hand use applies. In case of Left hand use, turn the headstage to the left 90 degrees so that the printed "L" is facing the user.

In order to connect the headstage with the coarse movement manipulator MN-2, you must screw the supplied connecting rod into the back of the headstage. When Right hand use applies, screw the connecting rod into the hole marked "R". For Left hand use, screw the connecting rod into the hole marked "L".

After mounting the headstage completely to the microscope, rotate the knobs of the Controller so as to make sure that each knob is controlling the correct axis.

The Controller

The Controller is made up of three operation knobs (1) (2) (5) which control independent movement along all three axes.

Working Distance

Headstage: X-axis

Y-axis

Z-axis

Fine Movement

Movable Distance 10mm each

Controller: X, Y and Z Direction

Fine Movement

Controllable Distance 10mm each

One rotation of the knob results in the movement of the microdrive by 500 microns, while the minimum scale of the control knob for X, Y and Z stands for 2 microns.

Accessories

| | | |
|--------------------|------|------|
| (1) Pipette Holder | H-7 | 1 ea |
| (2) Ball Joint | B-8C | 1 ea |

Handling and Maintenance of the Instrument

This precision instrument is delicate and should be handled with care. Avoid any shock to the instrument. Be aware that pulling on the hydraulic lines can result in damaging the sealed hydraulic system. Keep in mind that this system is sensitive to temperature change. To minimize unwanted movement of the headstage, keep MO-203 in a stable temperature environment away from drafts and sun.

After long term use, the oil may change color. This is due to oxidation of the oil. This change should not affect the instrument's performance.

After each use turn all three vernier controls to their zero positions in order to prevent excessive oil leakage through diaphragm. (A small amount of oil leakage is inevitable and should not be regarded as a defect in the device.)

For best results when operating the MO-203 each of the vernier controls should be at the mid-range of their 10mm travel.

Never attempt to disassemble a control cylinder. If so, this will make re-adjustment very difficult.

The oil containers of the microdrives and controller are of a cartridge design so that repair is a matter of replacing the cartridge.

If problems occur with the system, please do not attempt to repair, but rather contact us and we will repair it for you.